



EN

# Full Manual

**ISM-52F0021WMB**

# TABLE OF CONTENT

- ABOUT THIS DOCUMENT ..... 4**
- SAFETY INSTRUCTIONS ..... 5**
- OPEN SOURCE SOFTWARE LICENSE INFORMATION ..... 7**
- 1 - OPERATION ..... 9**
  - 1.1 - Access from a browser ..... 9
  - 1.2 - Live View Page ..... 11
    - 1.2.1 - General controls .....11
    - 1.2.2 - Control toolbar .....12
  - 1.3 - Playback ..... 13
  - 1.4 - Network Camera Setup ..... 15
    - 1.4.1 - Basic Configuration .....15
    - 1.4.2 - Video & Image .....15
    - 1.4.3 - Audio .....25
    - 1.4.4 - Event .....26
    - 1.4.5 - System .....42
  - 1.5 - Help ..... 54
- 2 - APPENDIX ..... 55**
  - 2.1 - Troubleshooting ..... 55
  - 2.2 - Alarm Connection ..... 56
  - 2.3 - Preventive Maintenance ..... 56
  - 2.4 - System Requirement for Web Browser ..... 57
  - 2.5 - General Performance Considerations ..... 57



## ABOUT THIS DOCUMENT

In this document you will find a comprehensive description of a specific series of devices, which we have prepared with great care and accuracy in order to provide you with a deep insight into the general functions and features that characterize this series of devices.

However, you should be aware that the detailed characterization presented in this document is based on the general product line. The individual feature set of specific models or designs within this series may vary depending on their configuration.

The variations may be reflected in an expanded or limited scope of functions and features, thus the actual specifications of individual products may differ in some respects from the designs set forth in this document.

For this reason, we strongly recommend that you thoroughly consult the specific data sheet for the product in question. The data sheet contains specific, detailed information tailored to the particular model. It is the primary reference document that provides the most authentic and accurate information on the individual functionality and features of each specific product in our device series.

We thank you for your understanding and willingness to invest time in acquiring accurate knowledge about the specific product you have selected from our device series. Please do not hesitate to contact us should you have any further questions or require additional information.

## SAFETY INSTRUCTIONS

Read the safety instructions and the operating instructions carefully before installing the product.

Depending on the product type, individual points may be omitted.

EN

### Mounting & Installation

- Ensure that the intended mounting location is suitable for the respective product (e.g. in terms of weight).
- Securely fasten the products to the locations and surfaces recommended by the manufacturer to ensure stability and safety.
- Ensure that the products are weatherproof when installed outdoors, e.g. protect cameras from direct sunlight or extreme temperatures.
- Make sure that any ventilation slots are not blocked to ensure sufficient air circulation and cooling.
- Make sure that cameras, switches, etc. are installed with sufficient safety distance to flammable materials, power sources, running water, etc.
- Assembly, commissioning and maintenance may only be carried out by authorized specialist personnel in compliance with the relevant standards and guidelines.

### Power supply & wiring

- To ensure a safe power supply, use only power supplies and cables recommended by the manufacturer.
- Make sure that the cables are properly routed and protected from tampering and damage (e.g. kinking) to avoid power failures or short circuits (e.g. due to moisture ingress).
- Make sure that the cables are not routed through doors, windows or other moving parts to avoid damage and tripping hazards.
- To disconnect the system from the power supply, pull the cable only by the plug and never directly by the cable.
- When shortening flexible connection cables, use wire end ferrules.

### Security

- Use strong passwords for all cameras and devices to prevent unauthorized access.
- Keep device firmware up to date to minimize security vulnerabilities.
- Protect (remote) access to the devices using secure methods such as encrypted connections or VPN.

## Operation

- The devices may only be operated within the temperature and humidity ranges specified in the data sheet.
- Sufficient ventilation must be provided to prevent overheating. This applies in particular to devices such as recorders and switches that can generate heat.
- Ensure that no sight lines are blocked and that accessories do not obscure areas used by other equipment or people.
- Ensure cameras are oriented to provide a clear view of the desired area without interfering with people's privacy.

## Cleaning & Maintenance

- Clean the lenses and housings of the cameras regularly to ensure a clear view.
- Keep the ventilation slots clean and free of dust to ensure efficient cooling.
- Use a mild detergent for cleaning. Harsh cleaning agents such as thinner or benzine may permanently damage the surface.
- Check the product regularly for damage and signs of wear.
- Only use original spare parts (e.g. connection cable) or accessories from VIDEOR E. Hartig GmbH.
- Any tampering by unauthorized persons will void the warranty.
- Before opening the housing, disconnect the power supply.

## Warning, Privacy & Legal Notices

- Draw the attention of visitors to the fact that they are being recorded by means of clearly visible notices.
- If necessary, point out rules of conduct.
- Ensure that cameras are oriented in such a way that privacy is not violated, e.g., by recording neighbours or public areas.
- Comply with local laws and regulations on video surveillance and data protection (GDPR).

## OPEN SOURCE SOFTWARE LICENSE INFORMATION

The software components provided with eneo products may contain copyrighted software that is licensed under various open source software licenses. For detailed information about the contained open source software packages, the used package versions, license information and complete license terms, please refer to...

- the open source information included in your products user interface,
- the product detail pages on the eneo website ([www.eneo-security.com](http://www.eneo-security.com)),
- the eneo download portal (<https://datacloud.videor.com/s/eneodownloadportal>). In case that previous link is broken, the latest link to the eneo download portal can be found on the respective eneo product page at [www.eneo-security.com](http://www.eneo-security.com).
- the download package of your firmware. The complete open source software license information of your product is included in the corresponding software download package that can be found in our download portal.

If you are missing any information, please contact [opensource@eneo-security.com](mailto:opensource@eneo-security.com), we will of course be happy to provide you with the missing information and will also make the missing information available to the public.

If you want to get access to the open source components (source codes) used in our products, please contact [opensource@eneo-security.com](mailto:opensource@eneo-security.com).



## 1 - OPERATION

The network camera can be used with Windows operating system and browsers. The recommended browsers are Internet Explorer, Safari, Firefox, Opera and Google Chrome with Windows

EN

**i NOTE:** To view streaming video in Microsoft Internet Explorer, set your browser to allow ActiveX controls.

### 1.1 - Access from a browser

1. Start a browser (Internet Explorer).
2. Enter the IP address or host name of the network camera in the Location/Address field of your browser.
3. You can see a log-in setup page. Set the ID and Password

**i NOTE:** A password can be used if it satisfies two or more in the following criteria:

1. 1. It contains at least one lowercase English character.
2. 2. It contains at least one uppercase English character.
3. 3. It contains at least one special character. The special characters are: !@#\$%^&\*()-+ ...
4. 4. It contains at least one digit.

Its length must be at least 10 if it satisfies only two of the above criteria.

4. Enter the ID and password to enter web page

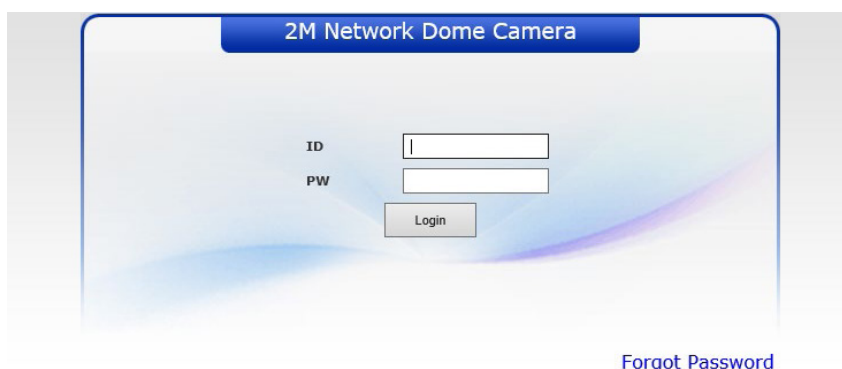

To prevent network eavesdropping when setting the admin password, this can be done via an encrypted HTTPS connection, which requires an HTTPS certificate (see NOTE below). To set the password via a standard HTTP connection, enter it directly in the first dialog shown below. To set the password via an encrypted HTTPS connection, please see 3. 4. 5. System > Security > HTTP & HTTPS

**i NOTE:** HTTPS(Hypertext Transfer Protocol over SSL) is a protocol used to encrypt the traffic between web browsers and servers. The HTTPS certificate controls the encrypted exchange of information.

5. Three menu pop up appears when user enter ID, Password



6. Click the Setup menu, User can see a setup page.

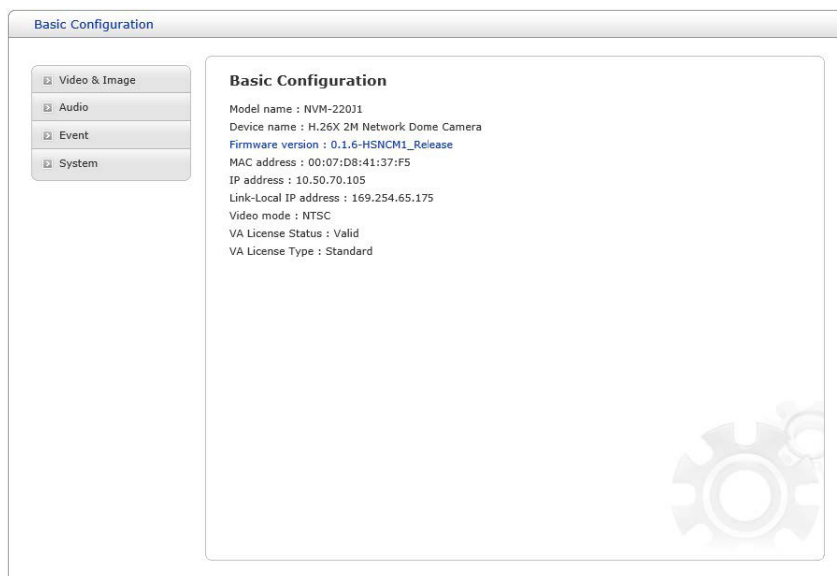

7. If User forgot Password, click "Forgot Password" button.

**i NOTE:** Contact Distributor or Seller with MAC address and Valid date. They provide a One-time password. Login with One-time password, User can change password. Please refer to "System>Security>User"







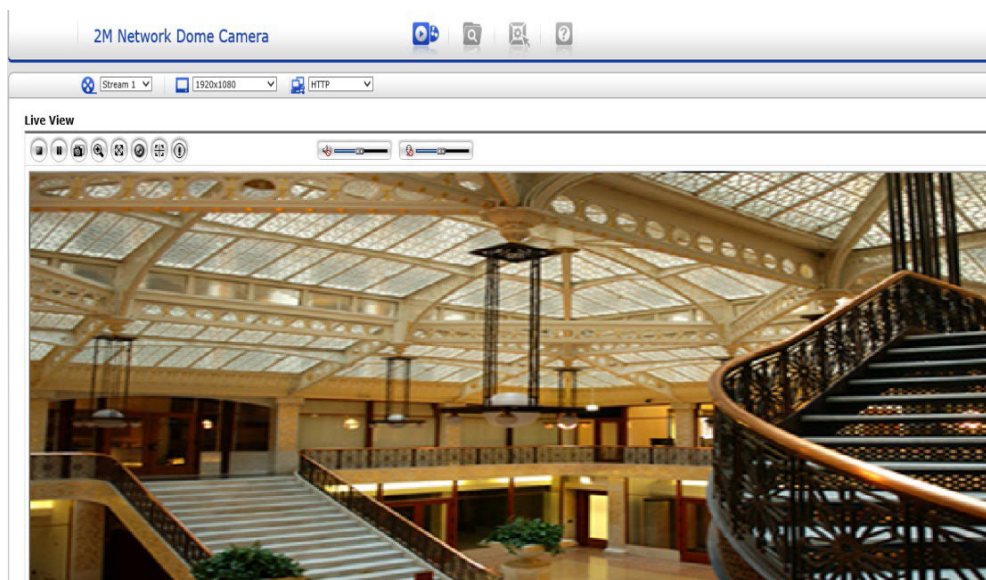

## 1.2 - Live View Page

The Live View page comes in several screen modes. Users are allowed to select the most suitable one out of those modes. Adjust the mode in accordance with your PC specifications and monitoring purposes.

EN

















### 1.2.1 - General controls

No.	Item	Description
1	 Live View Page	Show live view
2	 Playback Page	View recording data in the micro SD local storage
3	 Setup Page	Set page all function of camera
4	 Help Page	Description of each icon
5	 Stream	The video drop-down list allows you to select a customized or pre-programmed video stream on the Live View page. Stream profiles are configured under Setup > Basic Configuration > Video & Image. For more information, please see Basic Configuration > Video & Image of User Manual.
6	 Resolution	The resolution drop-down list allows you to select the most suitable one out of video resolutions to be displayed on Live View page
7	 Protocol	The protocol drop-down list allows you to select which combination of protocols and methods to use depending on your viewing requirements, and on the properties of your network.

## 1.2.2 - Control toolbar

The live viewer toolbar is available in the web browser page only. It displays the following buttons

No.	Item	Description
1	 Stop	Stops the video stream being played. Pressing the key again toggles the start and stop. The Start button connects to the network camera or starts playing a video stream.
2	 Pause	Pauses the video stream being played.
3	 Snapshot	Takes a snapshot of the current image. The location where the image is saved can be specified.
4	 Digital Zoom	Activates a zoom-in or zoom-out function for video image on the live screen.
5	 Full Screen	Causes the video image to fill the entire screen area. No other windows will be visible. Press the <b>Esc</b> button on the computer keyboard to cancel full screen view.
6	 Lens Control	Control Zoom and Focus manually. <b>Zoom:</b> Click  button to zoom out and click  button to zoom in. Or drag the bar to adjust the zoom. The focus is moved slightly after adjusting zoom; adjust the focus again, as necessary. <b>Focus:</b> Click  button to Near focus and click  button to Far focus. Or drag the bar to adjust the focus. <b>Smart Focus:</b> User can get automated focus here. <b>Calibrate:</b> Calibrate focus and zoom.
7	 Smart Focus	Set the focus to the optimum position.
8	 Relay Output	Manually triggers relay out.
9	 Speaker	Activates/Deactivates external speaker
10	 Mic	Activates/Deactivates microphone input.
11	 Control bar	Use this scale to control the volume of the speakers and microphones.

## 1.3 - Playback

The Playback window contains a list of recordings made to the memory card. It shows each recording's start time, length, the event type used to start the recording, calendar and time slice bar indicates if the recording is existed or not

EN

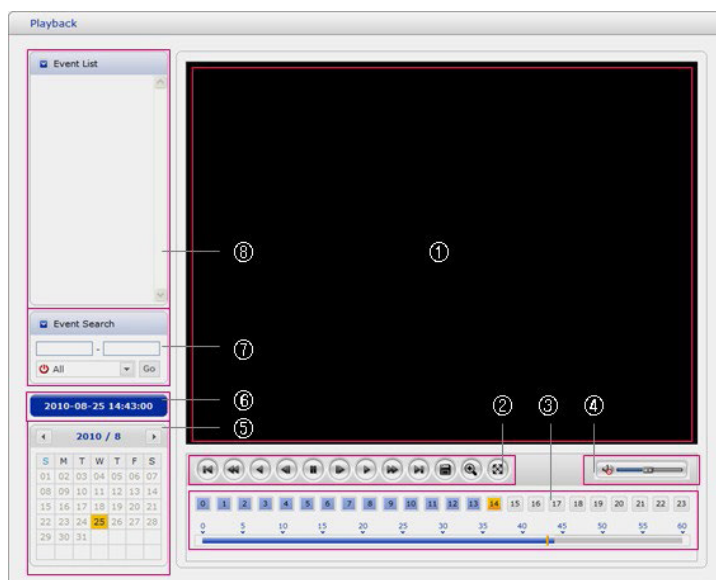

No.	User Group	Authority
1	Video Screen	You can see the video screen when playing the video clip in the Micro SD memory.
2	Playback Buttons	To view a recording data in the SD local storage, select it from the list and click the Playback buttons.
	Go to the first	Go to the beginning of the video clip.
	Fast backward play	Fast play backward of the video clip.
	Backward play	Play backward of the video clip.
	Step backward play	Go back one frame of the video clip.
	Pause	Pause playback of the video clip.
	Step forward play	Go forward one frame of the video clip.
	Forward play	Play forward the video clip.
	Fast forward play	Play fast forward of the video clip.
	Go to the last	Go to the end of the video clip.
	Clip copy	Copy the video clip.
	Zoom In	Zoom in the video clip.
Full Screen	Display full screen of the video.	
3	Time Chart	Display an hour-based search screen for the chosen date. If there is recording data, a blue section will be displayed on a 24-hour basis. If you select a particular hour in the chart, a yellow square on the hour will be displayed.
4	Speaker Control Bar	Search results from the SD local storage in the network camera connected are displayed monthly. If there is a recorded data for a particular date, a blue square on the date will be displayed. If you select a particular date in the calendar, a yellow square on the date will be displayed.

No.	User Group	Authority
5	Search Calendar	Search results from the SD local storage in the network camera connected are displayed monthly. If there is a recorded data for a particular date, a blue square on the date will be displayed. If you select a particular date in the calendar, a yellow square on the date will be displayed.
6	Play Time	Displays time of the video playing.
7	Event Search Window	Select a search option in the drop-down list and click <b>GO</b> button. You can also enter the time period for searching. If you click Start Date or End Date zone, displays Search Calendar.
8	Event List Window	Event List displays the event(s) that were recorded in the SD local storage. Select a list and click the play button. The video clip will be played.

## 1.4 - Network Camera Setup

### 1.4.1 - Basic Configuration

EN

You can see the device information in this information page.

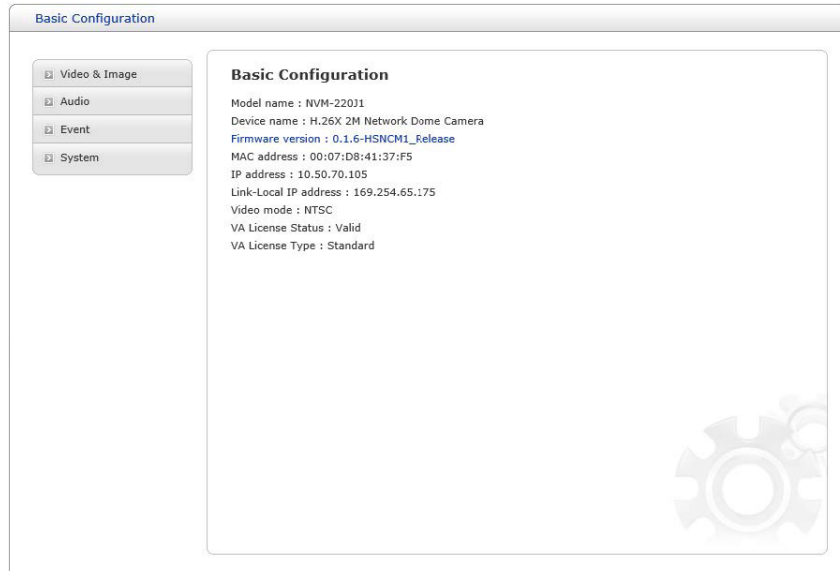

### 1.4.2 - Video & Image

#### Basic

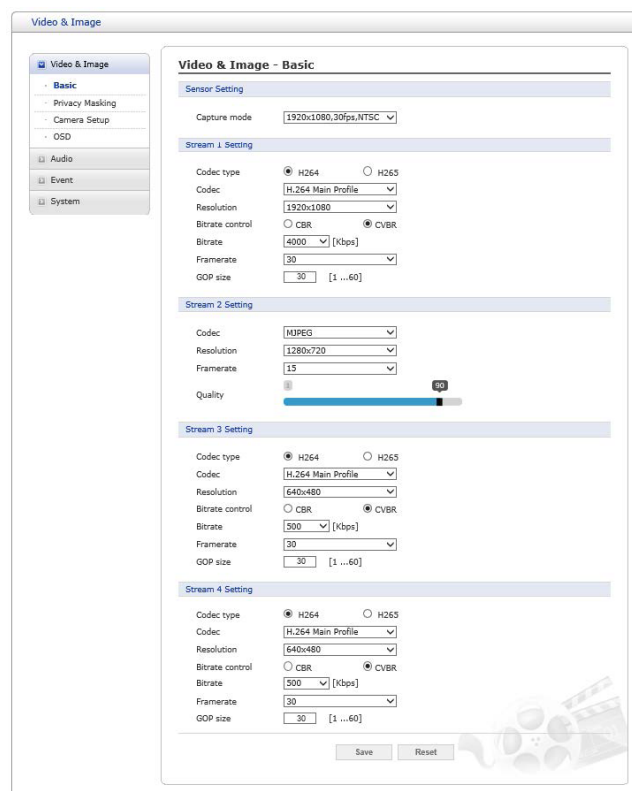

No.	Item	Description
1	Sensor Setting	<p><b>Capture mode</b> User can select sensor capture mode between 1920x1080(2MP) and NTSC/PAL (Some models are fixed to NTSC or PAL).</p>
2	Stream 1 Setting	<p><b>Codec</b> The codec supported in Stream 1 is H.264 and H.265. There are 3 pre-programmed stream profiles available for quick set-up. Choose the form of video encoding you wish to use from the drop-down list:</p> <ul style="list-style-type: none"> <li>• H.264 High Profile Primary profile for broadcast and disc storage applications, particularly for high-definition television applications (for example, this is the profile adopted by the Blu-ray Disc storage format and the DVB HDTV broadcast service).</li> <li>• H.264/H.265 Main Profile Primary profile for low-cost applications that require additional error robustness, this profile is used rarely in videoconferencing and mobile applications; it does add additional error resilience tools to the Constrained Baseline Profile. The importance of this profile is fading after the Constrained Baseline Profile has been defined.</li> <li>• H.264 Baseline Profile: Originally intended as the mainstream consumer profile for broadcast and storage applications, the importance of this profile faded when the High Profile was developed for those applications.</li> </ul> <p><b>Resolution</b> This enables users to determine a basic screen size when having an access through the Web Browser or PC program. The screen size control comes in several modes. Users can change the selected screen size anytime while monitoring the screen on a real-time basis.</p> <p><b>Bitrate control</b> The bit rate can be set as Constrained Bit Rate (CBR) or Constrained Variable Bit Rate (CVBR). Limiting the maximum bit rate helps control the bandwidth used by the H.264 or H.265 video stream. Leaving the Maximum bit rate as unlimited maintains consistently good image quality but increases bandwidth usage when there is more activity in the image. Limiting the bit rate to a defined value prevents excessive bandwidth usage, but images are degraded when the limit is exceeded.</p> <ul style="list-style-type: none"> <li>• <b>CBR:</b> Constrained bitrate.</li> <li>• <b>CVBR:</b> VBR with maximum bitrate which is set in Bitrate.</li> <li>• <b>Bitrate:</b> Maximum bitrate for CBR in the range of 100kbps ~10Mbps.</li> </ul> <p><b>Frame rate</b> Upon the real-time play, users should select a frame refresh rate per second. If the rate is high, the image will become smooth. On the other hand, if the rate is low, the image will not be natural but it can reduce a network load.</p> <p><b>GOP size</b> Select the GOP (Group of Picture) size. If users want to have a high quality of fast image one by one, please decrease the value. For the purpose of general monitoring, please do not change a basic value. Such act may cause a problem to the system performance.</p>
3	Stream 2 Setting	<p>Sometimes the image size is large due to low light or complex scenery. Adjusting the frame rate and quality helps to control the bandwidth and storage used by the Motion JPEG video stream in these situations. Limiting the frame rate and quality optimizes bandwidth and storage usage, but may give poor image quality. To prevent increased bandwidth and storage usage, the Resolution, Frame rate, and Frame Quality should be set to an optimal value.</p> <ul style="list-style-type: none"> <li>• <b>MJPEG Resolution:</b> Same as the stream 1 setting.</li> <li>• <b>MJPEG Frame rate:</b> Same as the stream 1 setting.</li> <li>• <b>MJPEG Quality:</b> Select the picture quality. If users want to have a high quality of fast image one by one, please decrease the value. For the purpose of general monitoring, please do not change a basic value. Such act may cause a problem to the system performance.</li> </ul>
4	Stream 3, Stream 4 Setting	Same as the Stream 1 settings
5	Save/Reset	When the settings are complete, click Save button to save the settings, or click Reset button to clear all of the information you entered without saving it.

## Privacy Masking

The privacy masking function allows you to mask parts of the video image to be transmitted. You can set up to four privacy masks. Select Enable privacy masking first and click Add Mask. User can set up to four privacy masks

EN

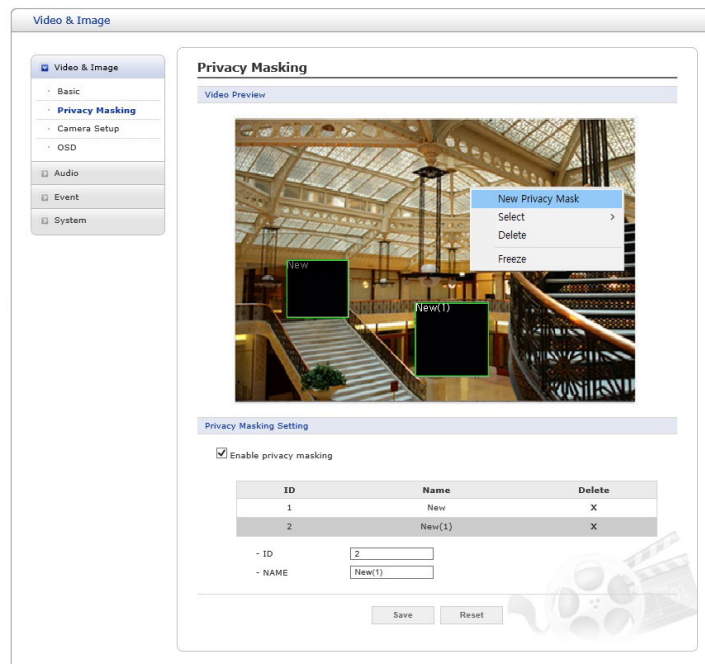

No.	Item	Description
1	Privacy Masking Setting	Select "Enable privacy masking" first and Save Button
2	New Privacy Mask	Click <b>right mouse button</b> on the preview window shows selection pop-up of New Privacy, Select, Delete and Freeze. Select <b>New Privacy Mask</b> generates an Include Black box of green line. Drag corner or line resizes and drag inside moves the box. User can select any box by clicking name on the preview window or click on the list. User can delete selected zone via right mouse click selection for a selected box, or click any one of X button in the zone list.
3	ID/NAME	User can change privacy mask ID/NAME.
4	Save/Reset	When the settings are complete, click <b>Save</b> button to save the settings, or click <b>Reset</b> button to clear all of the information you entered without saving it.

## Camera Setup

In this page, user can setup Exposure Control, White Balance Control, Image Appearance, and Day & Night control

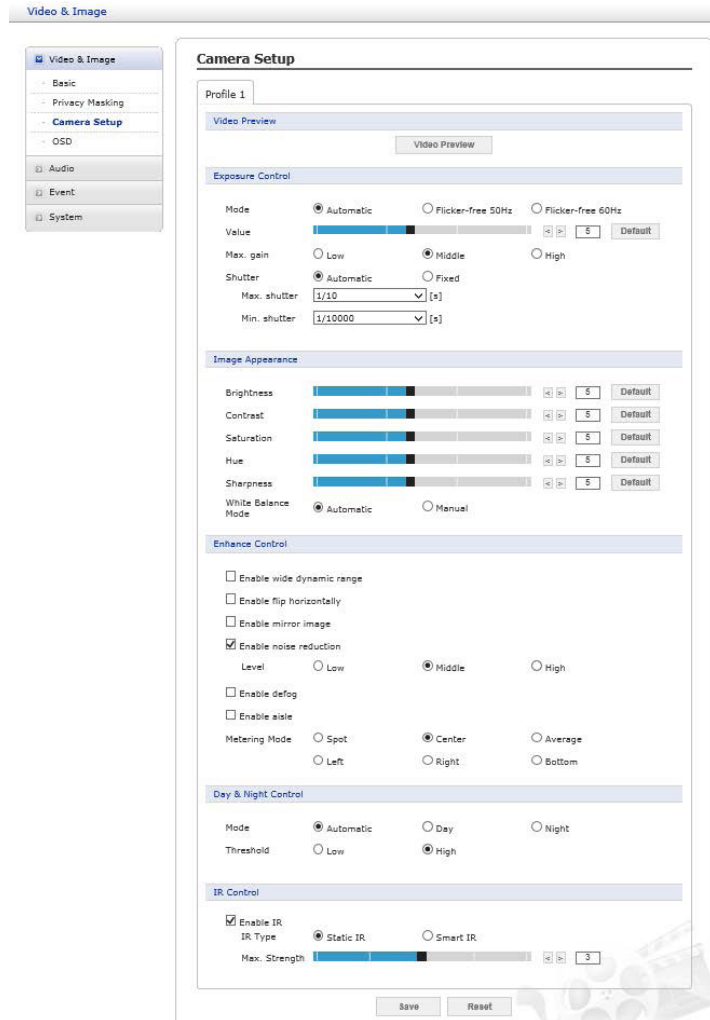

No.	Item	Description
1	Video Preview	User can check the setting via video preview pop-up window.

## Exposure Control

EN

**Exposure Control**

Mode  Automatic  Flicker-free 50Hz  Flicker-free 60Hz

Value

Max. gain  Low  Middle  High

Shutter  Automatic  Fixed

Max. shutter  [s]

Min. shutter  [s]

Enable DC-IRIS

No.	Item	Description
1	Mode	Determines exposure mode among automatic and flicker-free modes. Users can use Automatic mode with full shutter speed or Flicker-free mode with a limited range of shutter due to an anti-flicker function.
2	Value	Sets exposure value between 1 and 10 using slide bar or manual type in.
3	Max. gain	Sets maximum gain threshold.
4	Shutter	Sets shutter speed of the sensor. If users set Automatic, Max shutter and Min shutter can be selected. If the object is as fast as a car, please change the Max shutter to a faster value (e.g. 1/10 -> 1/120). If users set Manual, fixed shutter speed can be selected. <ul style="list-style-type: none"> <li>• <b>Max. shutter:</b> Users can set the limit for slow shutter speeds used in dark environments.</li> <li>• <b>Min. shutter:</b> Users can set the limit for fast shutter speeds used in bright environments.</li> </ul>
5	Enable DC-IRIS	Check this box to activate the DC-IRIS lens model.

## Image Appearance

### Image Appearance

Brightness 

Contrast 

Saturation 

Hue 

Sharpness 

White Balance Mode  Automatic  Manual

No.	Item	Description
1	Brightness	The image brightness can be adjusted in the range 1-10, where a higher value produces a brighter image.
2	Contrast	Adjust the image's contrast by raising or lowering the value in this field.
3	Saturation	Set an appropriate value in the range 1-10. Lower values mean less color saturation.
4	Hue	Set an appropriate value in the range 1-10. The value distinguishes color, such as red, yellow, green, or violet.
5	Sharpness	Set the amount of sharpening applied to the image. A sharper image might increase image noise especially in low light conditions. A lower setting reduces image noise, but the image would be less sharp.
6	White Balance Mode	Select white balance mode which fits camera installation environment. In case of Manual mode, user can set R, G, B gain manually.

## Enhance Control

### Enhance Control

- Enable wide dynamic range  
 Enable flip horizontally  
 Enable mirror image  
 Enable noise reduction  
 Level       Low       Middle       High  
 Enable defog  
 Enable aisle  
 Metering Mode     Spot       Center       Average  
                           Left       Right       Bottom

EN

No.	Item	Description
1	Enable wide dynamic range	Activates WDR which cannot be used with Defog function. If WDR is activated, shutter mode becomes automatic only. Once enabled, you can select WDR level.
2	Enable flip horizontally	Check this box to flip the image.
3	Enable mirror image	Check this box to mirror the image.
4	Enable noise reduction	Check this box to activate the noise reduction. Once enabled, you can select noise reduction level.
5	Enable defog	Check this box to activate the defog function. Once enabled, you can select defog level.
6	Enable aisle	Check this box to rotate image from 90 ° to 270°.
7	Metering Mode	Users can change the metering mode. * Metering Mode: Method of measuring the intensity of the light hitting and reflected by a subject in order to determine the exposure required.

## Day & Night Control

### Day & Night Control

Mode  Automatic  Day  Night  
 Threshold  Low  High

No.	Item	Description
1	Mode	<b>Automatic</b> Normally displays color image, and switches automatically to black & white image after the ambient light level reaches a pre-defined Threshold. <b>Day</b> Always displays color image. <b>Night</b> Always displays black & white image.
2	Threshold	<b>Low/High</b> Adjusts the level of light which the camera automatically switches between color and black & white image.
3	Smart Focus sync with Day & Night	Focus control automatically adjusts upon Day / Night change.

## Enhance Control

EN

IR Control

Enable IR

IR Type  Static IR  Smart IR

Max. Strength  3

IR Control

Enable IR

IR Type  Static IR  Smart IR

Speed  5

No.	Item	Description
1	Static IR	When switching to Night, IR is ON with the set value. <b>Max Strength:</b> Users can specify the intensity of the IR to prevent saturation of the image.
2	Smart IR	This function adjusts IR for appropriate brightness if it is dark even using the set Gain at Night switching. <b>Speed:</b> Users can adjust the control speed of the smart IR.
3	Save/Reset	When the settings are complete, click <b>Save</b> button to save the settings, or click <b>Reset</b> button to clear all of the information you entered without saving it.

This camera provides two OSD's (on screen display) on each stream, title and date & time. User can drag green "OSD Title" and "Date & Time" to the desired position and check at preview window.

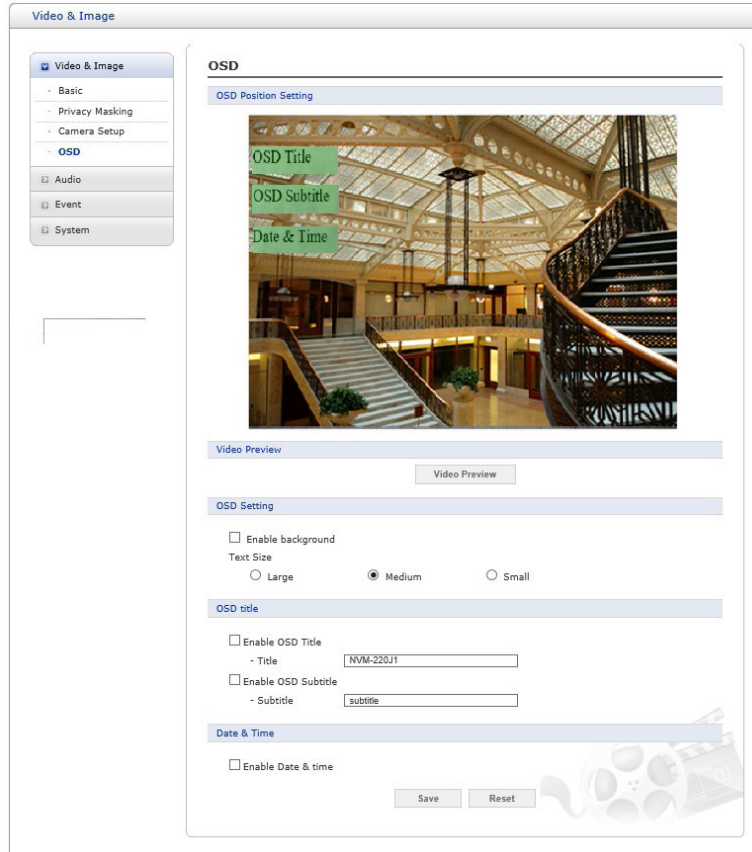

No.	Item	Description
1	OSD Position Setting	Click and move mouse to position OSD area.
2	Video Preview	User can check the position of OSD on actual video via preview pop- up window.
3	OSD Setting	User can determine show or hide OSD for each stream. <ul style="list-style-type: none"> <li>• <b>Enable background:</b> Since the OSD color is white, user can set background for visibility in black.</li> <li>• <b>Text size:</b> User can set text size between Large, Medium and Small.</li> </ul>
4	OSD title	<ul style="list-style-type: none"> <li>• <b>Enable OSD Title:</b> User can show or hide OSD title, and can change OSD title by type in. The default is the model name of the camera.</li> <li>• <b>Enable OSD Subtitle:</b> User can show or hide OSD subtitle and can change OSD subtitle by type in. The default is the Subtitle.</li> </ul>
5	Date & Time	Select <b>Enable Date &amp; Time</b> User can show or hide date & time on OSD.
6	Save/Reset	When the settings are complete, click <b>Save</b> button to save the settings, or click <b>Reset</b> button to clear all of the information you entered without saving it.

### 1.4.3 - Audio

The network camera can transmit audio to other clients using an external microphone and can play audio received from other clients by attaching a speaker. The Setup page has an additional menu item called Audio, which allows different audio configurations, such as full duplex and simplex.

No.	Item	Description
1	Audio Setting	Enable audio: Check the box to enable audio in the video stream. <ul style="list-style-type: none"> <li>• Compression type: G.711 <math>\mu</math>-law</li> <li>• Sample rate: 8KHz</li> <li>• Sound bit rate: 64Kbps</li> </ul>
2	Audio Input	Audio from an external line source can be connected to the STEREO Jack I/O of the network camera. <ul style="list-style-type: none"> <li>• <b>Input volume:</b> If there are problems with the sound input Being too low or high, it is possible to adjust the input gain for the microphone attached to the network camera.</li> <li>• <b>Mute:</b> User can disable the input audio transmission.</li> </ul>
3	Audio Output	<b>Enable full duplex</b> Check the box to enable Full Duplex mode. This means that you can transmit and receive audio (talk and listen) at the same time, without having to use any of the controls. This is just like having a telephone conversation. This mode requires that the client PC has a sound card with support for full-duplex audio. Uncheck the box enable Simplex mode. The simplex mode only transmits audio from the network camera to any web client. It does not receive audio from other web clients. <ul style="list-style-type: none"> <li>• <b>Output volume:</b> If the sound from the speaker is too low or high it is possible to adjust the output gain for the active speaker attached to the network camera.</li> <li>• <b>Mute:</b> User can disable the output audio transmission.</li> </ul>
4	Save/Reset	When the settings are complete, click <b>Save</b> button to save the settings, or click <b>Reset</b> button to clear all of the information you entered without saving it.

## 1.4.4 - Event

### Event In

#### On Boot

This is used to trigger an event every time the network camera is started.

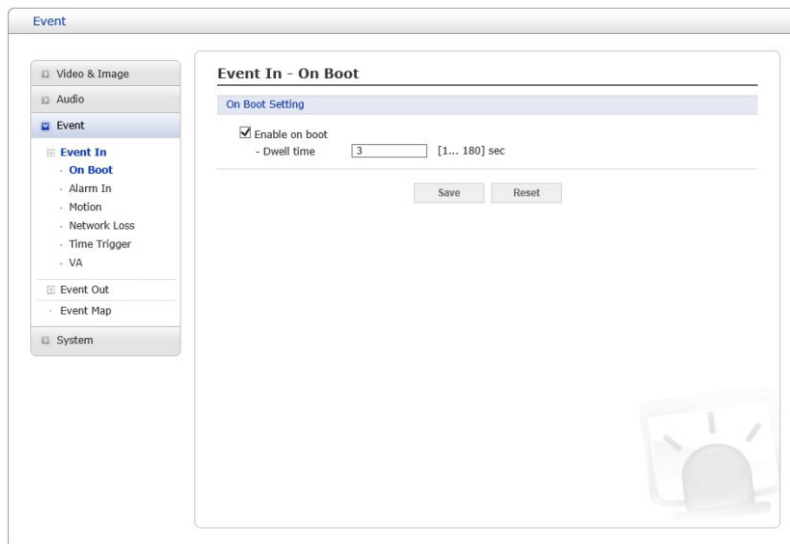

No.	Item	Description
1	Enable on boot	Select to activate the On Boot event
2	Dwell time	Enter the Dwell time the event lasts from the point of detection, 1-180 seconds.
3	Save/Reset	When the settings are complete, click <b>Save</b> button to save the settings, or click <b>Reset</b> button to clear all of the information you entered without saving it.

## Alarm In

This camera provides 1 Alarm In port and user can set the port. The Port can be given as Normally Open or Normally Close state, and its Normal state can be configured. In order to use the alarm port, check the **Enable alarm port 1** first.

EN

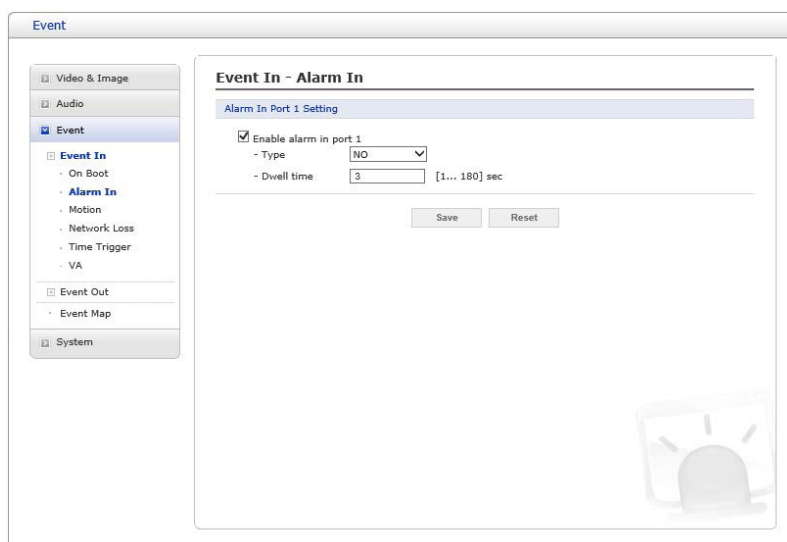

No.	Item	Description
1	Alarm In Port 1 Setting	<p><b>Type</b> Choose the type of alarm to use from the drop-down list, NO (Normally Open) or NC (Normally Closed).</p> <p><b>Dwell Time</b> Set the dwell time an event lasts from the point of detection of an alarm input.</p>
2	Save/Reset	When the settings are complete, click <b>Save</b> button to save the settings, or click <b>Reset</b> button to clear all of the information you entered without saving it.

## Motion

This option makes use of the motion detection function click right button of the mouse.

Include, Exclude zones each Max 4.

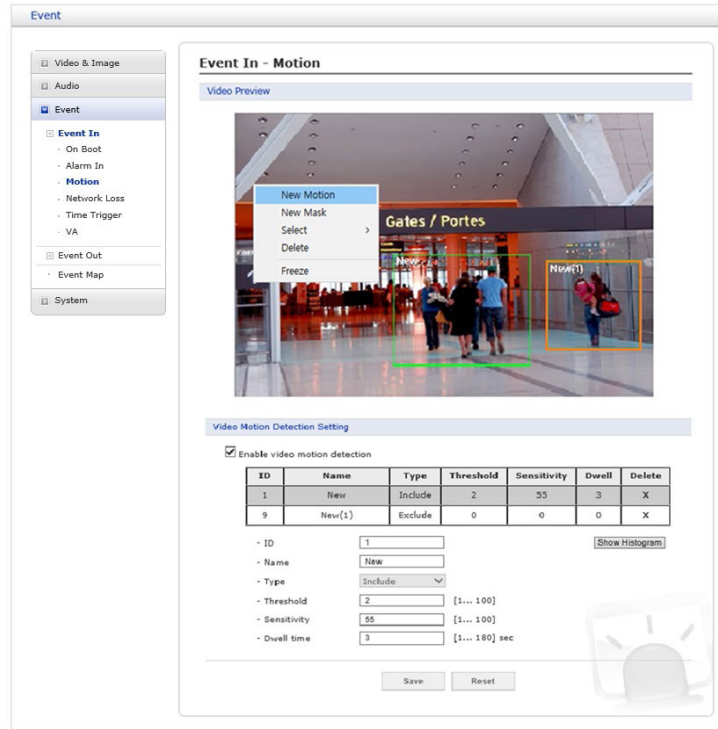

No.	Item	Description
1	Video Preview	Click right mouse button on the preview window shows selection pop-up of New Motion, New Mask, Select, Delete and Freeze. Select New Motion and click & drag generates an Include box of green color, New Mask and click & drag generates an Exclude box of orange color. Drag corner or line resizes and drag inside moves the box. User can select any box by clicking name on the preview window or click on the list. User can delete selected zone via right mouse click selection for a selected box, or click any one of X button in the zone list.
2	Video Motion Detection Setting	Select <b>Enable video motion detection</b> to activate motion detection.
3	ID	Order of generation, <b>Include</b> 1~8, <b>Exclude</b> 9~16.
4	Name	User definable zone name.
5	Type	Shows zone type and cannot be changed. <ul style="list-style-type: none"> <li>• <b>Threshold:</b> Determines how large the motion in the zone can trigger event in percentage.</li> <li>• <b>Sensitivity:</b> User can change sensitivity of this function, where large value sets more sensitive detection.</li> <li>• <b>Dwell time:</b> Determines how long the triggered event holds from the last triggering.</li> </ul>
6	Show Histogram	This camera provides live histogram for easy setup of threshold level in motion window. The pop-up window shows activity strength and threshold level, and user can determine threshold level for triggering motion event by slide bar or type in number. <ul style="list-style-type: none"> <li>• <b>Threshold:</b> Determines how large the motion in the zone can trigger event in percentage.</li> <li>• <b>Change interval:</b> Determines the interval of the Sensitivity scale.</li> </ul>
7	Save/Reset	When the settings are complete, click <b>Save</b> button to save the settings, or click <b>Reset</b> button to clear all of the information you entered without saving it.

## Network Loss

This is used to trigger an event every time the network connection is failed.

Select **Enable network loss** to activate the Network Loss event. Select a dwell time for how long the event will last from the point of detection.

EN

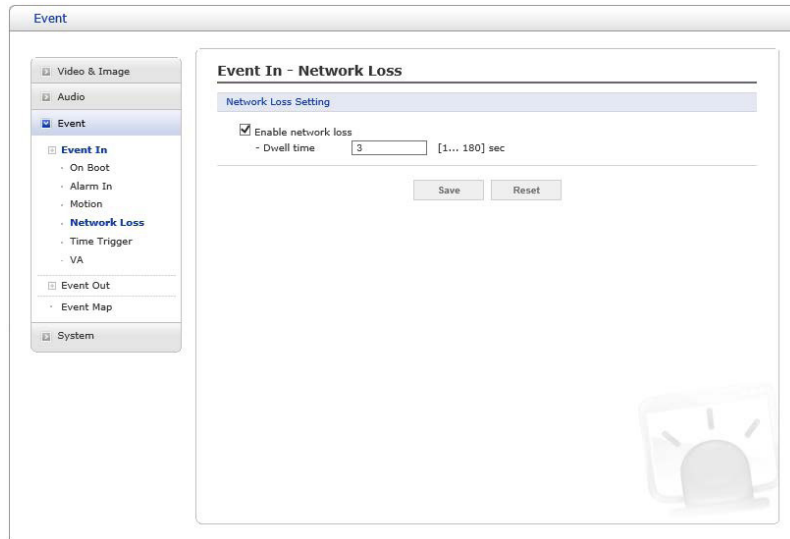

No.	Item	Description
1	Enable network loss	Select to activate the Network Loss event
2	Dwell time	Select a dwell time for how long the event will last from the point of detection, 1-180 seconds.
3	Save/Reset	When the settings are complete, click <b>Save</b> button to save the settings, or click <b>Reset</b> button to clear all of the information you entered without saving it.

## Time Trigger

Time Trigger is to set alarms at specific time. User can set up to four time triggers and each time trigger can be set to specific date in the calendar, every day, day of the week, or date of every month.

Select **Enable time trigger** to activate the Time Trigger function.

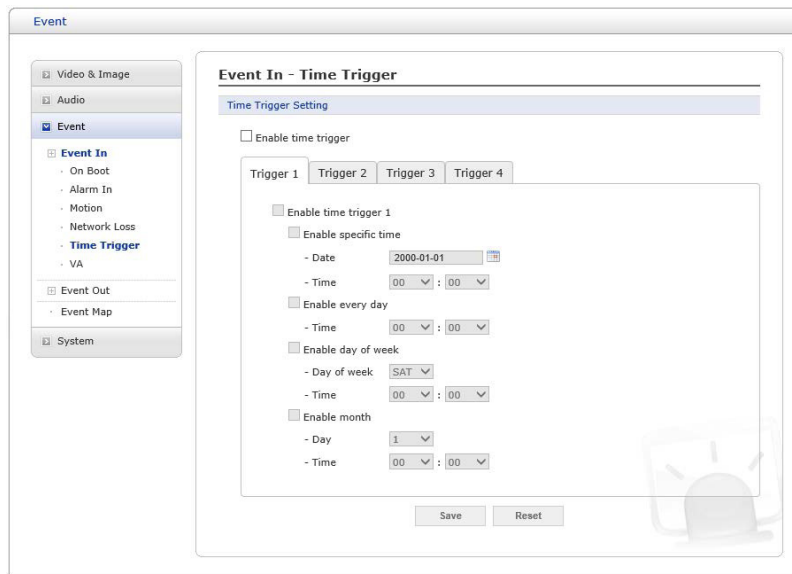

No.	Item	Description
1	Enable specific time	User can select a date in the calendar or type in date, and specify time for event trigger.
2	Enable every day	Trigger event every day at specified time.
3	Enable day of week	Trigger event at the day of every week at specified time.
4	Enable month	Trigger event at the date of every month at specified time.
5	Save/Reset	When the settings are complete, click <b>Save</b> button to save the settings, or click <b>Reset</b> button to clear all of the information you entered without saving it.

## Video Analysis

The network cameras provide VA (Video Analysis) functions.

EN

### Event In - Video Analysis

#### Video Preview



#### Video Content Analysis Setting

Enable video content analysis

##### View Rule

Motion       Intrusion       Exclusive  
 Line       Loitering

##### Object

Sensitivity       
 Min width size       
 Min height size       
 Max width size       
 Max height size       
 Show object size

Detection Rule				
1	None	Rule Name	<input type="text"/>	<input type="checkbox"/> off
2	None	Rule Name	<input type="text"/>	<input type="checkbox"/> off
3	None	Rule Name	<input type="text"/>	<input type="checkbox"/> off
4	None	Rule Name	<input type="text"/>	<input type="checkbox"/> off
5	None	Rule Name	<input type="text"/>	<input type="checkbox"/> off
6	None	Rule Name	<input type="text"/>	<input type="checkbox"/> off
7	None	Rule Name	<input type="text"/>	<input type="checkbox"/> off
8	None	Rule Name	<input type="text"/>	<input type="checkbox"/> off

##### Exclusive Area

- Exclusive Area  off

#### Video Control



**Release Background** Press this button to recognize the background again.



Scene type   
 View mode

No.	Item	Description
1	Video Content Analysis Setting	Click the <b>Enable video content analysis</b> check box. <ul style="list-style-type: none"> <li>• <b>Standard Type:</b> Intelligent Motion, Intrusion Detector, Tampering</li> <li>• <b>Advanced Type:</b> Intelligent Motion, Intrusion Detector, Tampering, Line Detect, Loitering, Human Detector.</li> </ul>
2	View Rule	In setting VA Event, users can select events to be displayed in Video Preview.
3	Object	Users can set Object settings. <ul style="list-style-type: none"> <li>• Sensitivity allows users to set the object sensitivity to be detected. If there is a lot of noise (shaking leaves, etc.) on the screen, lower the Sensitivity.</li> <li>• Users can set the object size to be detected by Min / Max size adjustment.</li> <li>• Select Show object size to display the object size set in Video Preview.</li> </ul> <p><input type="checkbox"/> Object size recommended settings</p> <ul style="list-style-type: none"> <li>• Indoor installation (in 10m, based on average height): Sensitivity 80 Min width 2 height 6 Max width 50 height 60.</li> <li>• Outdoor installation (in 30m, based on car): Sensitivity 80 Min width 2 height 4 Max width 60 height 50.</li> </ul>

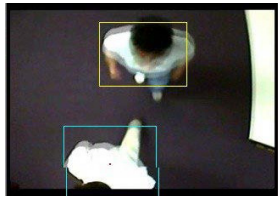

A malfunction may occur under the following conditions.

- Dark environment.
- Changes in brightness due to lighting variations or clouds.
- When a moving object or facility is engaged or overlapped.
- When directing the camera to a light source (e.g. cars in a tunnel, trains).
- When a shadow occurs.
- When trees and plants are shaking in the wind (If possible, install the camera in a location free of trees and other plants. If it is inevitable, specify the area as Exclusive Area.)
- Changes of fountain.
- An environment where reflections occur, such as rivers, lakes, glass, windows, mirrors, etc. (If possible, install the camera in a location where there are no reflective objects. If it is inevitable, specify the area as Exclusive Area)
- If the object size is less than 5% or more than 40% on the screen.
- When the brightness changes due to AGC or IRIS operation of the camera.
- When an object with a minor difference from its background and brightness moves.
- Bad weather conditions such as typhoon, snow, rain.
- If the object size changes significantly due to movement toward the camera.
- When passing behind an object such as a tree.
- When the movement is feeble.
- When moving at high speed.
- If there are too many moving objects, it is difficult to create a background (for example, a subway platform at commute time)
- When the image is shaken due to camera shake.
- When there is a flashing light in the shooting area
- If the camera lens is not clear or out of focus.

Situation	Default set image	Recommended settings	Modified set image
Two objects are detected as one	 <p>In this scene, two objects are detected as one. This is usually due to the maximum size of the object that is not set correctly. Reduce the maximum size of the object.</p>	<p>Generally, when setting the minimum and maximum sizes, the average size should be set to the minimum size of the object, half the width and height of the object, and the maximum size of the object should be about 130% of the width and height of the average object.</p>	 <p>By adjusting the maximum size, two people are detected as separate objects.</p>
One object is detected as two	 <p>In this scene, one object is detected as two objects. Usually this is because the minimum and maximum sizes are set incorrectly. Increase the minimum and maximum size of the object.</p>		 <p>Increasing the minimum and maximum sizes will ensure that objects are accurately detected as one.</p>
High amount of noise in image	<p>Some scenes contain large amounts of noise, which can have an undesirable effect on the image analysis because unwanted objects are detected in the image or unwanted events occur.</p>	<p>To minimize the noise, reducing the sensitivity will only detect visible objects.</p>	<p>Users can ignore the noise in the image and still detect the object in the scene.</p>

No.	Item	Description
1	Detection Rule	<p>Set VA Event. Select Event in the Select box (default: None). When Event is selected, a menu for setting Rule Name and Event will be displayed. Users can set Event in Video Preview with on/off toggle switch.</p> <p> The number of Detection Rule differs depending on License Type. (Standard Type: 3 Advanced Type: 8)</p>
2	How to set up	<p><b>Line Detector:</b></p> <ol style="list-style-type: none"> <li>Click the None menu to change into Line Detector.</li> <li>Enter the Rule Name and select the Line Event type from the Counter menu. The Detector will generate an event when an object passes over the set line. Counter sets the direction and generates an event when an object moves in the set direction and increases the count. To reset the count, click the Reset button.</li> <li>Set direction of line detection in Direction menu.</li> <li>Enable the on / off toggle switch to on and set the line area in Video Preview</li> </ol> <p><b>Tampering:</b></p> <ol style="list-style-type: none"> <li>Click the None menu to change into Tampering.</li> <li>Enter the Rule Name and set the Dwell time. Tampering generates an event if there is a scene change. Users can adjust the tampering sensitivity in the Sensitivity menu.</li> <li>In the Light Change menu, users can include lighting on / off as a tampering event. Users can adjust the sensitivity of Light Change in the Light Sensitivity menu.</li> </ol> <p><b>Intelligent Motion:</b></p> <ol style="list-style-type: none"> <li>Click the None menu to change into Intelligent Motion.</li> <li>Enter the Rule Name and set the Dwell time. Intelligent Motion generates an event when motion is detected in the set area. Users can adjust the sensitivity of Intelligent Motion in the Sensitivity menu.</li> <li>Enable the on / off toggle switch to on and set the Intelligent Motion area in Video Preview. The Intelligent Motion area is displayed as a blue cell.</li> </ol> <p> When Intelligent Motion is enabled, the existing Motion Detection is disabled.</p>

No.	Item	Description
2	How to set up	<p><b>Intrusion:</b></p> <ol style="list-style-type: none"> <li>1. Click the None menu to change into Intrusion.</li> <li>2. Enter the Rule Name. Intrusion occurs when an object enters, appears or exits in/from set area.</li> <li>3. Enable the on / off toggle switch to on and set the Intrusion area In Video Preview. The Intrusion area is displayed as a yellow cell.</li> </ol> <p><b>Loitering:</b></p> <ol style="list-style-type: none"> <li>1. Click the None menu to change into Loitering.</li> <li>2. Enter the Rule Name. Loitering generates an event if an object enters a set area and walks or stays for more than the set time.</li> <li>3. Enable the on / off toggle switch to on and set the Loitering area in Video Preview. The Loitering area is displayed as a purple cell.</li> </ol> <p><b>Human:</b></p> <ol style="list-style-type: none"> <li>1. Click the None menu to change into Human.</li> <li>2. Enter the Rule Name. Human</li> </ol> <p> Conditions for distinguishing human:</p> <ul style="list-style-type: none"> <li>• The object must be 10-20% of the screen size.</li> <li>• Head and shoulders should be visible and moving.</li> </ul> <p><b>The camera may not be able to distinguish human in the following situations:</b></p> <ul style="list-style-type: none"> <li>• A person who is sitting, crawling, or lying.</li> <li>• Shooting vertically from the ceiling.</li> <li>• When a head is unseen</li> <li>• A person carrying a big baggage</li> <li>• A person riding a bicycle</li> <li>• People moving closer together</li> <li>• Shown less than a second</li> </ul>

Situation	Default set image	Recommended settings	Modified set image
Scene with swaying trees	 <p>This scene involves many unwanted movements from the tree. These movements can cause unwanted objects to be detected during image analysis.</p>	<p>Reduce the sensitivity to avoid tree movement. As an alternative, users can set the area around the tree to Exclusive Area.</p>	 <p>This setting avoids the detection of tree movement during the image analysis.</p>

No.	Item	Description
1	Exclusive Area	Set the area to disable Object detection By not handling unnecessary areas, users can reduce false alarms and CPU usage. Only Object-based events are not generated. Motion and Tampering runs irrespective of Exclusive Area.
2	How to set up	<p>Enable the on / off toggle switch to on and set the Exclusive Area in Video Preview. The Exclusive Area is displayed as red cells.</p> <p><b>Video Control:</b></p> <p>Users can make settings for optimal image analysis.</p> <p>Click the Relearn Background button to re-learn the current image as background.</p> <p>Use the Scene type menu to select the place where the camera is installed.</p> <p>Use the View mode menu to select the angle at which the camera is installed.</p> <p> View mode</p> <p>Overhead is generally suitable for counting or detecting a moving direction.</p> <p>Angle is suitable for detecting intrusions.</p> <p>Horizontal should only be used for home security.</p> <p><b>Proper camera installation</b></p> <p>Installation height: 2.5m ~ 3.0m</p> <p>Installation type: Tilt about 30 degrees horizontally and face downward.</p> <p>Object: The object must not be within 3 meters of the camera.</p>
3	Save/Reset	When the settings are complete, click <b>Save</b> button to save the settings, or click <b>Reset</b> button to clear all of the information you entered without saving it.

## Event Out

### SMTP (E-Mail)

EN

The network camera can be configured to send event and error email messages via SMTP (Simple Mail Transfer Protocol).

No.	Item	Description
1	SMTP (E-Mail) Setting	<p><b>Enable SMTP</b> Select <b>Enable SMTP</b> to activate the SMTP operation.</p> <p><b>Sender</b> Enter an email address to be used as the sender for all messages sent by the network camera.</p> <p><b>Interval</b> Represents the time interval of the email notification when events occur several times.</p> <p><b>Aggregate events</b> Shows the maximum number of emails sent within each interval.</p> <p><b>Use Mail Server</b> Check the box if you are using a mail server to receive event notification and image email.</p> <ul style="list-style-type: none"> <li>• <b>Mail Server:</b> Enter the host names (or IP addresses) for your mail server.</li> <li>• <b>Port:</b> Enter the port number for your mail server.</li> <li>• <b>Connection security:</b> Select a connection security type in the drop-down. (None / Start TLS / SSL)</li> <li>• <b>Enable use (SMTP) authentication:</b> Check the box if your mail server requires authentication.</li> <li>• <b>User name/Password:</b> Enter the User name and Password as provided by your network administrator or ISP (Internet Service Provider).</li> <li>• <b>Login method:</b> Choose a log-in method in the drop-down (AUTH LOGIN / AUTH PLAIN)</li> </ul>
2	SMTP (E-Mail) Receiver	<p><b>Receiver #</b> User can assign up to 8 receivers Enter an email address.</p>
3	SMTP (E-Mail) Test	<p><b>Receiver</b> User can check the SMTP setting via a sample email. Enter an email address and click the Test button to test that the mail servers are functioning and that the email address is valid.</p>
4	Save/Reset	When the settings are complete, click <b>Save</b> button to save the settings, or click <b>Reset</b> button to clear all of the information you entered without saving it.

When the network camera detects an event, it can record and save images to an FTP server. Images can be sent as e-mail attachments. Check the **Enable FTP** box to enable the service. This camera can support multiple FTP servers and user can configure each server settings separately.

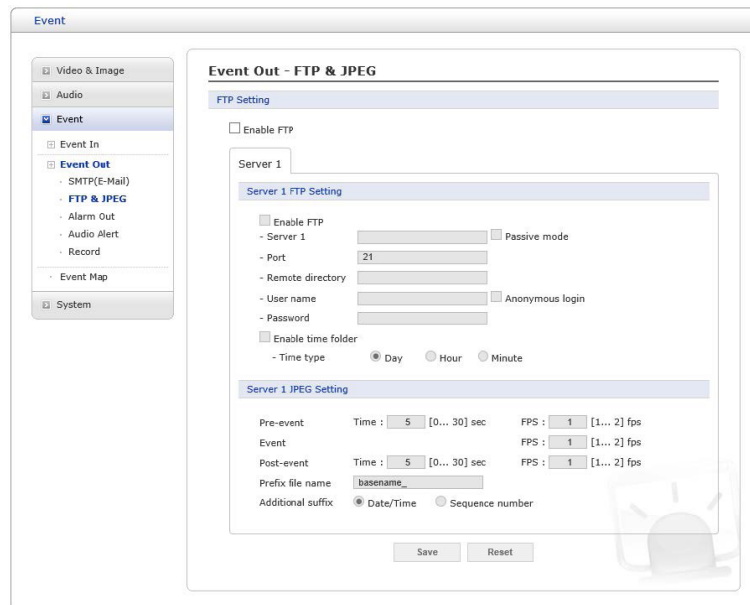

No.	Item	Description
1	FTP Setting	<p><b>Server</b> Enter the server's IP address or host name. Note that a DNS server must be specified in the TCP/IP network settings if using a host name.</p> <p><b>Port</b> Enter the port number used by the FTP server. The default is 21.</p> <p><b>Passive mode</b> Under normal circumstances the network camera simply requests the target FTP server to open the data connection. Checking this box issues a PASV command to the FTP server and establishes a passive FTP connection, whereby the network camera actively initiates both the FTP control and data connections to the target server. This is normally desirable if there is a fire- wall between the camera and the target FTP server.</p> <p><b>Remote directory</b> Specify the path to the directory where the uploaded images will be stored. If this directory does not already exist on the FTP server, there will be an error message when uploading.</p> <p><b>User name/Password</b> Provide your log-in information</p> <p><b>Anonymous login</b> Check the box if you want to use anonymous login method and the server supports it.</p> <p><b>Time type</b> The name of the folder where the uploaded image will be saved can be set as the date, time, and minute of the event.</p>
2	JPEG Setting	<p><b>Pre-event</b> A pre-event buffer contains images from the time immediately preceding the event trigger. These are stored internally in the server. This buffer can be very useful when checking to see what happened to cause the event trigger. Check the box to enable the pre-trigger buffer, enter the desired total length in seconds, minutes or hours, and specify the required image frequency.</p> <p><b>Post-event</b> This function is the counterpart to the pre-trigger buffer described above and contains images from the time immediately after the trigger. Configure as for pre-even.</p> <p><b>Prefix file name</b> This name will be used for all the image files saved. If suffixes are also used, the file name will take the form &lt;prefix&gt;&lt;suffix&gt;.&lt;extension&gt;</p> <p><b>Additional suffix</b> Add either a date/time suffix or a sequence number, with or without a maximum value.</p>
3	Save/Reset	When the settings are complete, click <b>Save</b> button to save the settings, or click <b>Reset</b> button to clear all of the information you entered without saving it.

## Alarm Out

When the network camera detects an event, it can control external equipment connected to its alarm output port.

EN

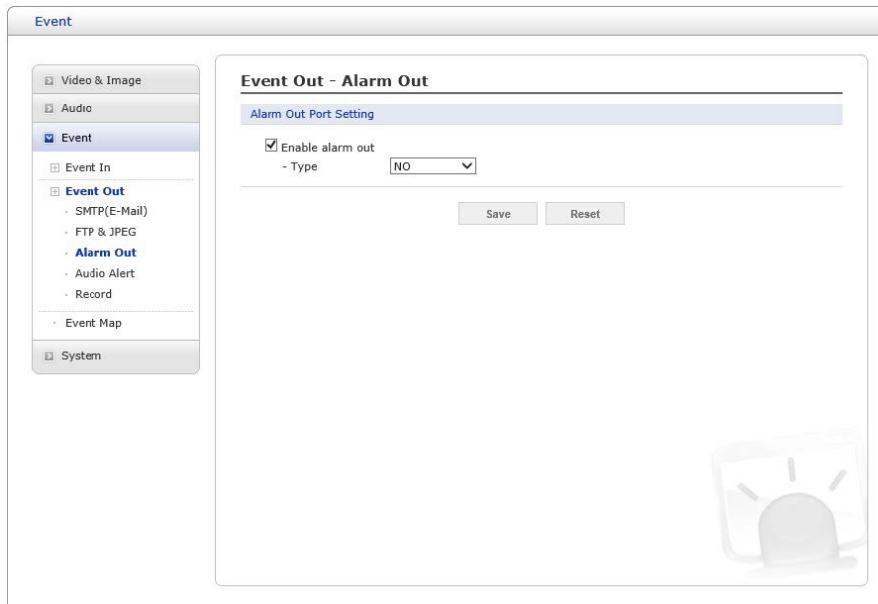

No.	Item	Description
1	Alarm Out Port Setting	<p><b>Enable alarm out</b> If selected, the output becomes activated for as long as the event is active.</p> <p><b>Type</b> Select a type of NO (Normally Open) or NC (Normally Closed).</p>
2	Save/Reset	When the settings are complete, click <b>Save</b> button to save the settings, or click <b>Reset</b> button to clear all of the information you entered without saving it.

## Audio Alert

When the network camera detects an event, it can output a predefined audio data to external speaker.

Check the **Enable audio alert** box to enable the service.

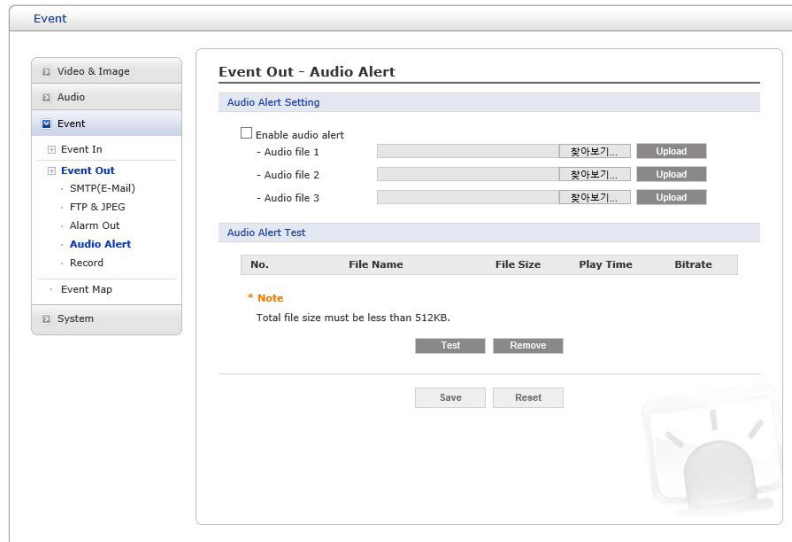

No.	Item	Description
1	Audio Alert Setting	<p><b>Enable audio alert</b> If selected, the output becomes activated for as long as the event is active.</p> <p>To use the audio alert with the network camera, an audio data file made by user must be uploaded from your PC. Provide the path to the file directly, or use the Browse button to locate it. Then click the Upload button. Up to 3 audio files are available. The total file size must be less than 512 KB.</p>
2	Audio Alert Test	<p>When the setup is complete, the audio output can be tested by clicking the Test button. To remove an audio file, select the file and click the Remove button.</p>
3	Save/Reset	<p>When the settings are complete, click <b>Save</b> button to save the settings, or click <b>Reset</b> button to clear all of the information you entered without saving it.</p>

## Record

When the network camera detects an event, it can record the video stream onto the Micro SD Memory (not supplied) or NAS (Network Attached Device) as a storage device. Check the **Enable Record** box to enable the service.

EN

No.	Item	Description
1	Record Setting	<p><b>Override</b> Click checkbox to overwrite the storage device; Continuous Record is available when not using an SD card.</p> <p><b>Stream Type</b> You can select Stream 1, Stream 3, or Stream 4. • Stream1, 3, 4: H.264 data</p> <p><b>Pre-event</b> Enter pre-event time value for the storage device pre-recording.</p> <p><b>Post-event</b> Enter post-event time value for the storage device pre-recording.</p> <p><b>Audio Record</b> Check the box if you want to record audio with video.</p> <p> Stream2 MJPEG data cannot be recorded.</p>
2	Record Schedule	You can set the weekly recording schedule for each day. Drag or click area by a box unit at first. Clicking the block toggles the recording between on and off. Click the All Select button to set a schedule for the entire week or a whole day, respectively.
3	Device Setting	SD: Mounted SD card.
4	Format	Click the Format button to format SD card.
5	Device Remove	Click the Device Remove button before detaching SD card for data safety in the SD card.
6	Device Information	Show current SD card information.

## Event Map

The event map allows you to change the settings and establish a schedule for each event trigger from the network camera.

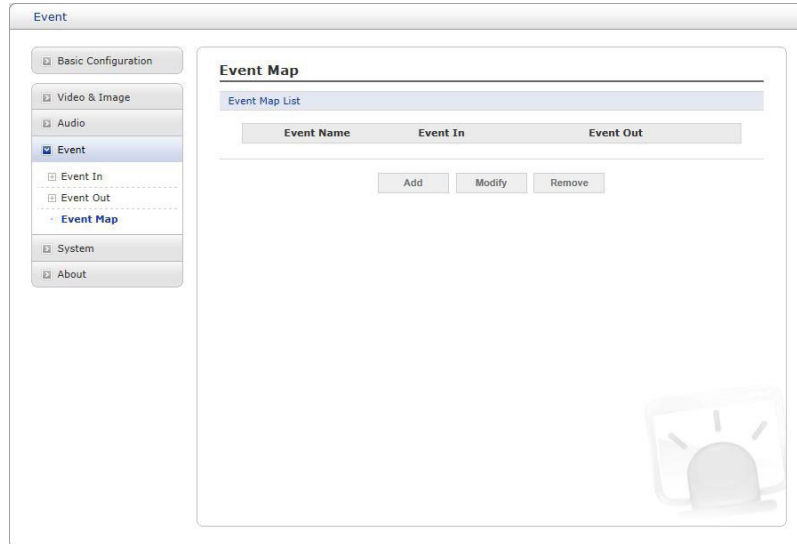

Click the **Add** button to make a new event map; a popup window displays as below. To change an existing event, select that event and click the **Modify** button; this same window will display and the information can be changed as required. Selecting an event and clicking **Remove** deletes the event.

### Add Event Map

General	
Name	<input type="text" value="New Event"/>
Event In	
Type	<input type="text" value="Onboot"/>
Event Out	
<input type="checkbox"/> E-Mail	
<input type="checkbox"/> To e-mail address 1	<input type="text"/>
<input type="checkbox"/> To e-mail address 2	<input type="text"/>
<input type="checkbox"/> To e-mail address 3	<input type="text"/>
<input type="checkbox"/> To e-mail address 4	<input type="text"/>
<input type="checkbox"/> To e-mail address 5	<input type="text"/>
<input type="checkbox"/> To e-mail address 6	<input type="text"/>
<input type="checkbox"/> To e-mail address 7	<input type="text"/>
<input type="checkbox"/> To e-mail address 8	<input type="text"/>
<input type="text" value="Subject"/> <input type="text" value="Additional info"/>	
<input type="checkbox"/> FTP	
<input type="checkbox"/> FTP Server 1	
<input type="checkbox"/> Alarm out	
<input type="checkbox"/> Audio alert	
<input checked="" type="radio"/> Audio file 1 <input type="radio"/> Audio file 2 <input type="radio"/> Audio file 3	
<input type="checkbox"/> Record	
<input type="button" value="OK"/> <input type="button" value="Cancel"/>	

No.	Item	Description
1	General	Enter the name for a new event map.
2	Event In	Select an event type in the drop-down list.
3	Event Out	<p><b>E-Mail</b> Select the email addresses you want to notify via email that an event has occurred.</p> <p><b>FTP</b> Select checkbox beside FTP to record and save images to an FTP server when an event has occurred.</p> <p><b>Alarm out</b> Check this box to enable the alarm out.</p> <p><b>Audio Alert</b> Select an Audio Alert file as the Network Transmitter output when audio alert event triggered. The Audio Alert file must first be configured on the Event In page.</p> <p><b>Record</b> Record video stream when an event has occurred. The Record option must first be configured on the Event Out page.</p>
4	Save/Reset	When the settings are complete, click <b>Save</b> button to save the settings, or click <b>Reset</b> button to clear all of the information you entered without saving it.

EN

## 1.4.5 - System

### Information

You can enter the system information. This page is very useful when you require device information after installation.

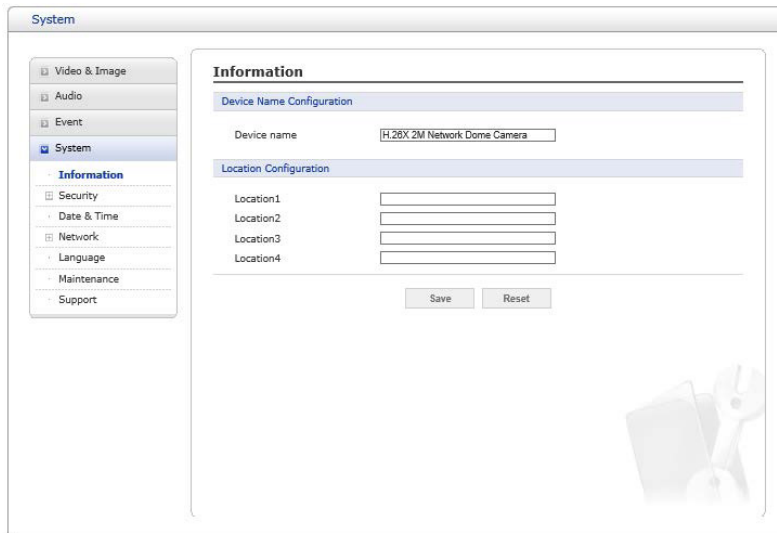

No.	Item	Description
1	Device Name Configuration	Enter the device name
2	Location Configuration	Enter the location information. You can enter up to four locations.
3	Save/Reset	When the settings are complete, click <b>Save</b> button to save the settings, or click <b>Reset</b> button to clear all of the information you entered without saving it.

## Security

### Users

EN

User access control is enabled by default when the administrator sets the root password on first access.

New users are authorized with user names and passwords.

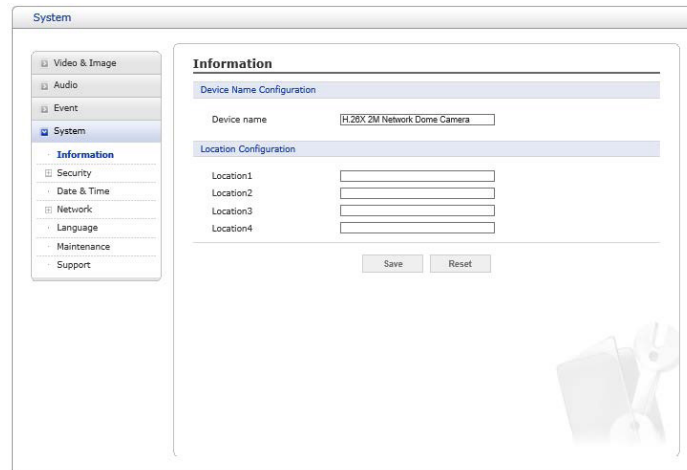

No.	Item	Description
1	User List Setting	<p>This section shows how to register a user account. Enter a user name and password to be added. User can select Authority between administrator, Operator and Guest. Each User group has different Authority.</p> <ul style="list-style-type: none"> <li>• <b>Administrator:</b> Live, Setup, System</li> <li>• <b>Operator:</b> Live, Setup</li> <li>• <b>Guest:</b> Live</li> </ul> <p>Register them by pressing the Add button. You will see the pop-up window as below.</p>

### Add User

---

User Setting

- User name :
- Password :
- Confirm password :

Passwords cannot contain the &, % special characters.

- User group : guest ▼

Enable Lens control

No.	Item	Description
1	Add User	Enter all information, user click OK button to save the setting or click Cancel Button to clear all of the information.
2	Save/Reset	When the settings are complete, click <b>Save</b> button to save the settings, or click <b>Reset</b> button to clear all of the information you entered without saving it.

## HTTP & HTTPS

For greater security, the network camera can be configured to use HTTPS (Hypertext Transfer Protocol over SSL (Secure Socket Layer)). Then all communication that would otherwise go via HTTP will instead go via an encrypted HTTPS connection.

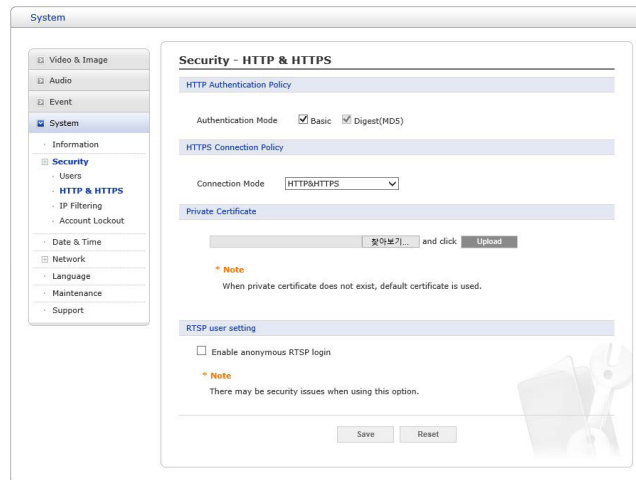

No.	Item	Description
1	HTTP Authentication Policy	<p><b>Basic</b> It is a form of encoding with Base64 by combining ID and password during authentication.</p> <p><b>Digest(MD5)</b> It is a form of encoding with MD5 (128bit hash value) by combining ID and password during authentication.</p>
2	HTTPS Connection Policy	<p>Choose the form of connection you wish to use from the drop-down list for the administrator, Operator and Viewer to enable HTTPS connection (set to HTTP by default).</p> <ul style="list-style-type: none"> <li>• HTTPS / HTTP &amp; HTTPS</li> </ul>
3	Privacy Certificate	To use HTTPS for communication with the network camera, an official certificate issued by a CA (Certificate Authority) must be uploaded from your PC. Provide the path to the certificate directly, or use the <b>Browse</b> button to locate it. Then click the <b>Upload</b> button.
4	RTSP user setting	Select enable anonymous RTSP login.
5	Save/Reset	When the settings are complete, click <b>Save</b> button to save the settings, or click <b>Reset</b> button to clear all of the information you entered without saving it.

**i NOTE:** Please refer to the home page of your preferred CA for information on where to send the request. For more information, please see the online help.

## IP Filtering

When the IP address filter is enabled, addresses added to the list are set as allowed or denied addresses. All other IP addresses not in this list will then be allowed or denied access accordingly, that is, if the addresses in the list are allowed, then all others are denied access, and vice versa. Also see the online help for more information.

EN

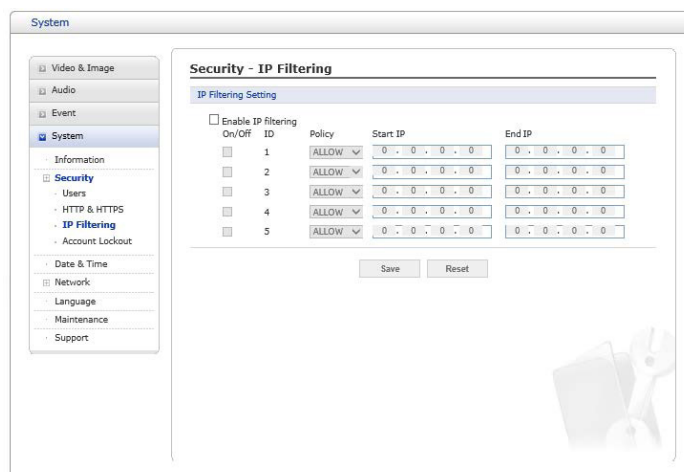

No.	Item	Description
1	Enable IP address filtering	Checking the box enables the IP address filtering function. Up to 256 IP address entries may be specified (a single entry can contain multiple IP addresses)
2	Add	Click the button to add new filtered addresses.
3	Save/Reset	When the settings are complete, click <b>Save</b> button to save the settings, or click <b>Reset</b> button to clear all of the information you entered without saving it.

**i NOTE:** Users from IP addresses that will be allowed must also be registered with the appropriate access rights. This is done from Setup > System > Security > Users.

## Account Lockout

Check the “Enable Account Lockout” box to enable the service

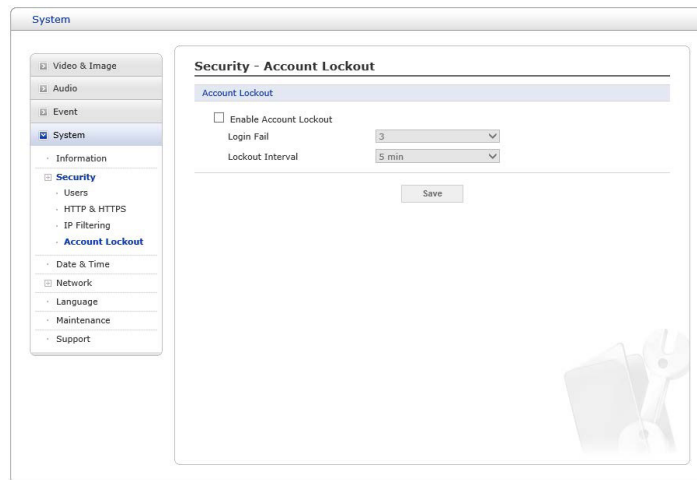

No.	Item	Description
1	Account Lockout	<p><b>Login Fail</b> User can set the number of login failures from 3 to 7. If you fail to log in more than the set number of times, user cannot log in for a Lockout Interval time period.</p> <p><b>Lockout Interval</b> If user fail more than the set number of Login Failures, User cannot log in for the set amount of time. User can choose between 5, 10, 20 and 30 minutes.</p>
2	Save	When the settings are complete, click Save button to save the settings.

## Date & Time

EN

No.	Item	Description
1	Current Server Time	This displays the current date and time (24h clock). The time can be displayed in 12h clock format (see below).
2	New Server Time	<p><b>Time zone</b> Select your time zone from the drop-down list. If you want the server clock to automatically adjust for daylight savings time, check the box <b>Automatically adjust for daylight saving time changes</b>.</p> <p><b>Time mode</b> Select the preferred method to use for setting the time:</p> <ul style="list-style-type: none"> <li>• <b>Synchronize with computer time:</b> Sets the time from the clock on your computer.</li> <li>• <b>Synchronize with NTP Server:</b> The network camera will obtain the time from an NTP server every interval setting time. User can choose between 1, 2, 3, 6, 12 and 24 hours.</li> <li>• <b>Set manually:</b> Allows you to manually set the time and date.</li> </ul>
3	Date & Time Format	<p>Specify the formats for the date and time (12h or 24h) displayed in the video streams. Select Date &amp; Time format from the drop-down list.</p> <ul style="list-style-type: none"> <li>• <b>Date Format</b> Specify the date format. YYYY: Year, MM: Month, DD: Day.</li> <li>• <b>Time Format</b> Specify the date format. 24 Hours or 12 Hours AM/PM.</li> </ul>
4	Save/Reset	When the settings are complete, click <b>Save</b> button to save the settings, or click <b>Reset</b> button to clear all of the information you entered without saving it.

## Network

### Basic

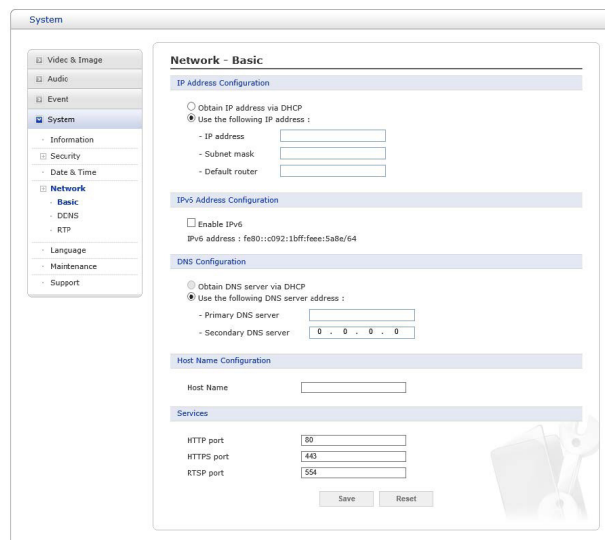

No.	Item	Description
1	IP Address Configuration	<p><b>Obtain IP address via DHCP</b> Dynamic Host Configuration Protocol (DHCP) is a protocol that lets network administrators centrally manage and automate the assignment of IP addresses on a network. DHCP is enabled by default. Although a DHCP server is mostly used to set an IP address dynamically, it is also possible to use it to set a static, known IP address for a particular MAC address. To obtain IP address via DHCP, check the radio button.</p> <p><b>Use the following IP address</b> To use a static IP address for the network camera, check the radio button and then make the following settings:</p> <ul style="list-style-type: none"> <li>• <b>IP address:</b> Specify a unique IP address for your network camera.</li> <li>• <b>Subnet mask:</b> Specify the mask for the subnet the network camera is located on.</li> <li>• <b>Default router:</b> Specify the IP address of the default router (gateway) used for connecting devices attached to different networks and network segments.</li> </ul>
2	IPv6 Address Configuration	Check the <b>Enable IPv6</b> box to enable IPv6. Other settings for IPv6 are configured in the network router.
3	DNS Configuration	<p>DNS (Domain Name Service) provides the translation of host names to IP addresses on your network. Check the radio button to obtain DNS server via DHCP or set the DNS server.</p> <p><b>Obtain DNS Server via DHCP</b> Automatically use the DNS server settings provided by the DHCP server.</p> <p><b>Use the following DNS server address</b> To enter the desired DNS server by specifying the following:</p> <ul style="list-style-type: none"> <li>• <b>DNS servers:</b> Enter the IP addresses of the primary and secondary DNS servers.</li> </ul>
4	Host Name Configuration	<p><b>Host Name</b> Enter the host name to be used as device information in the client software or Smart Manager.</p>
5	Services	<p><b>HTTP port</b> Enter a port to receive a service through the HTTP. Default port number is "80".</p> <p><b>HTTPS port</b> Enter a port to receive a service through the HTTPS. Default port number is "443".</p> <p><b>RTSP port</b> Enter a port to receive a service through the RTSP. Default port number is "554".</p>
6	Save/Reset	When the settings are complete, click <b>Save</b> button to save the settings, or click <b>Reset</b> button to clear all of the information you entered without saving it.

# DDNS

When using the high-speed Internet with the telephone or cable network, users can operate the network camera on the floating IP environment in which IPs are changed at every access. Users should receive an account and password by visiting a DDNS service like <http://www.dyndns.org/>.

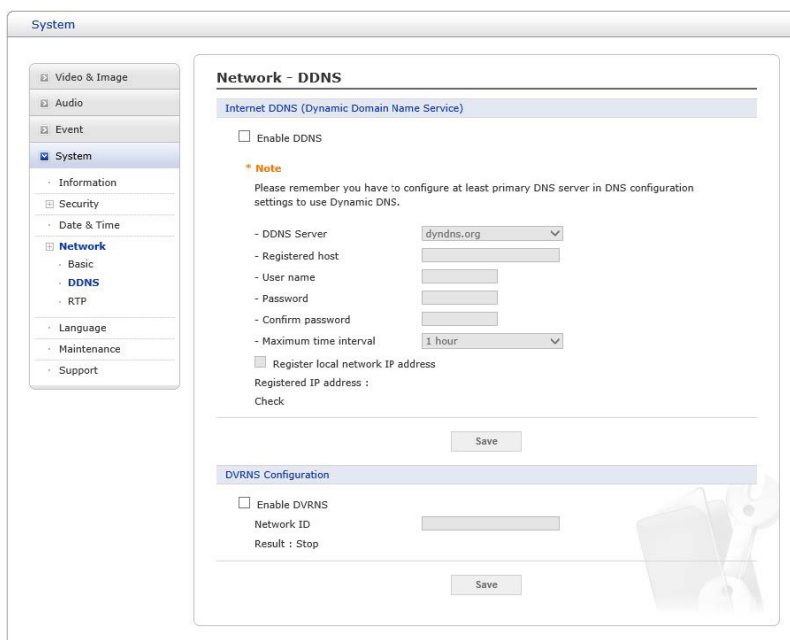

No.	Item	Description
1	Internet DDNS (Dynamic Domain Name Service)	<p><b>Enable DDNS:</b> Check to have DDNS service available.</p> <p><b>DDNS Server:</b> Select the DDNS server.</p> <p><b>Registered host:</b> Enter an address of the DDNS server.</p> <p><b>Username:</b> Enter an ID to access to the DDNS server.</p> <p><b>Password:</b> Enter a password to be used for accessing the DDNS server.</p> <p><b>Confirm password:</b> Enter the password again to confirm it.</p> <p><b>Maximum time interval</b> Set a time interval to synchronize with the DDNS server. Select the time interval from the drop-down list.</p> <p><b>Register local network IP address</b> Register a Network Video Server IP address to the DDNS server by checking the box and enter the Registered IP address.</p>
2	DVRNS Configuration	<p><b>Enable DVRNS:</b> Check to have DVRNS service available.</p> <p><b>Network ID:</b> Enter an ID to access to the DVRNS server.</p> <p><b>Result:</b> Connect status of DVRNS server.</p>
3	Save/Reset	When the settings are complete, click <b>Save</b> button to save the settings, or click <b>Reset</b> button to clear all of the information you entered without saving it.

Create a setting for sending and receiving an audio or video on a real-time basis. These settings are the IP address, port number, and Time-To-Live value (TTL) to use for the media stream(s) in multicast H.264 format. Only certain IP addresses and port numbers should be used for multicast streams.

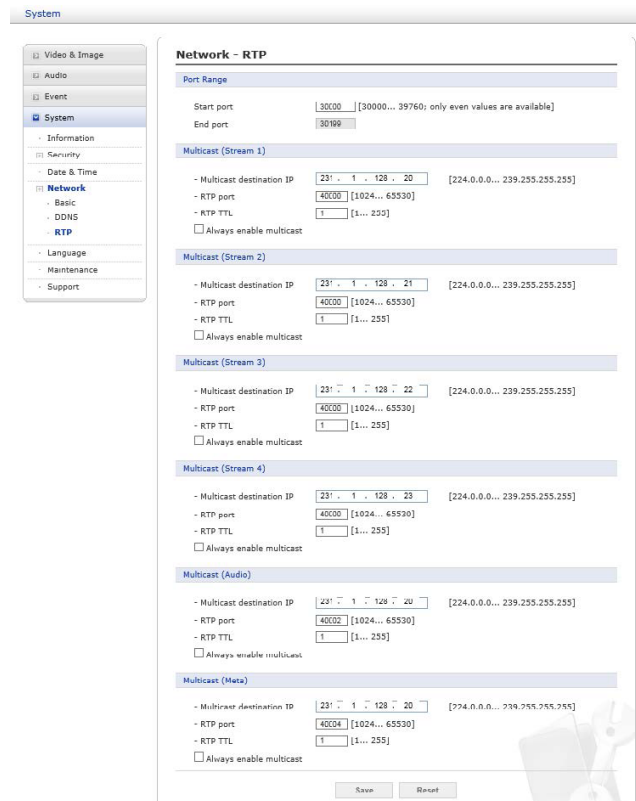

No.	Item	Description
1	Port Range	<b>Start/End port:</b> Enter a value between 30000 and 39760.
2	Multicast (Stream1/ Stream2/ Stream3/ Stream4/ Audio/ Meta)	<p>This function is for sending Video and Meta Data to Multicast group.</p> <ul style="list-style-type: none"> <li>• <b>Multicast destination IP:</b> Enter an IP between 224.0.0.0 and 239.255.255.255.</li> <li>• <b>RTP port</b> Enter a value between 1024 and 65532.</li> <li>• <b>RTP TTL</b> Enter a value between 1 and 255. If a network status is smooth, enter a lower value. However, if a network status is poor, enter a higher value. When there are many network cameras or users, a higher value may cause a heavy load to the network. Consult with a network manager for detailed information.</li> </ul> <p><b>Always enable multicast</b> Check the box to start multicast streaming without opening an RTSP session.</p>
3	Save/Reset	When the settings are complete, click <b>Save</b> button to save the settings, or click <b>Reset</b> button to clear all of the information you entered without saving it.

## Language

Select a user language. The language choices are Chinese, German, French, Japanese, Korean, English and Russian.

EN

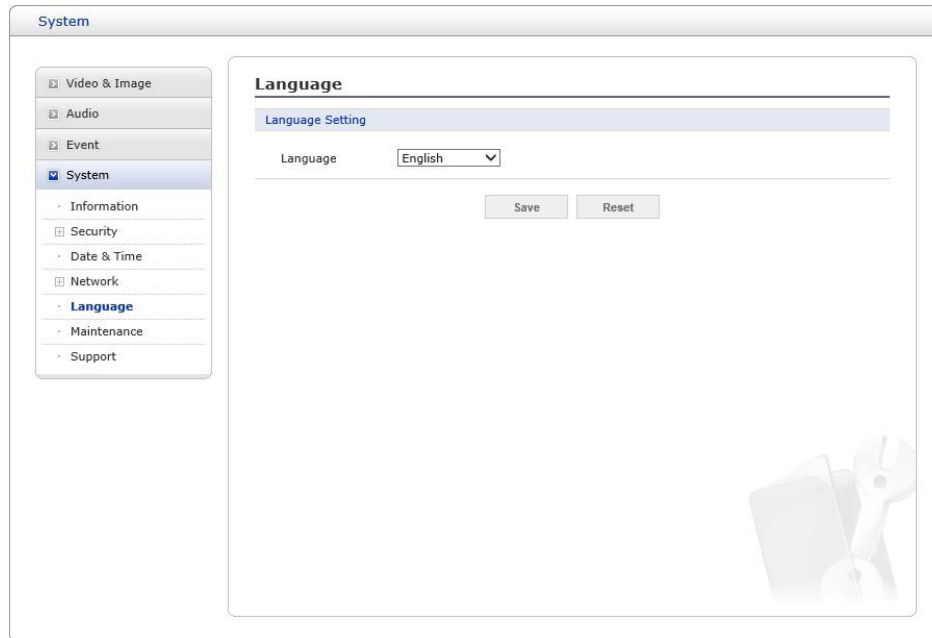

No.	Item	Description
1	Language Setting	The language choices are Chinese, German, French, Japanese, Korean, English and Russian.
2	Save/Reset	When the settings are complete, click <b>Save</b> button to save the settings, or click <b>Reset</b> button to clear all of the information you entered without saving it.

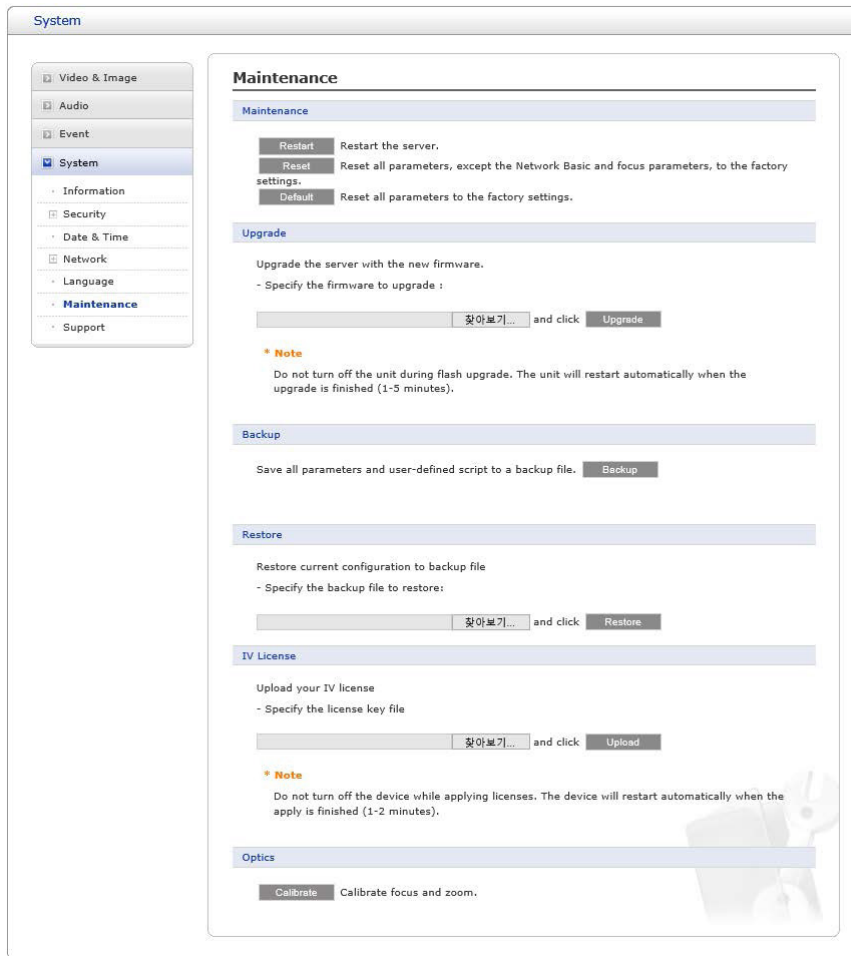

No.	Item	Description
1	Maintenance	<p><b>Restart</b> The unit is restarted without changing any of the settings. Use this method if the unit is not behaving as expected.</p> <p><b>Reset</b> The unit is restarted and most current settings are reset to factory default values. The settings that are not affected are: (the boot protocol (DHCP or static), the static IP address, the default router, the subnet mask, the system time)</p> <p><b>Default</b> The Default button should be used with caution. Pressing this will return all of the network camera's settings to the factory default values (including the IP address).</p>
2	Upgrade	Upgrade your camera by importing an upgrade file from PC and pressing the Upgrade button. During the upgrade, do not turn off the power of the network camera. Wait at least five minutes and then try to access the camera again.
3	Backup	Save the setting values that users have entered to the network camera to a user PC.
4	Restore	Import and apply a setting value previously saved to a user PC. <i>i</i> Backup and Restore can only be used on the same unit running the same firmware. This feature is not intended for multi-configurations or for firmware upgrades.
5	IV License	Import and apply Intelligent Video analytics license file.
6	Optics	Calibrate focus and zoom. <i>i</i> This menu appears for motorized lens model only.

## Support

The support page provides valuable information on troubleshooting and contact information, should you require technical assistance.

EN

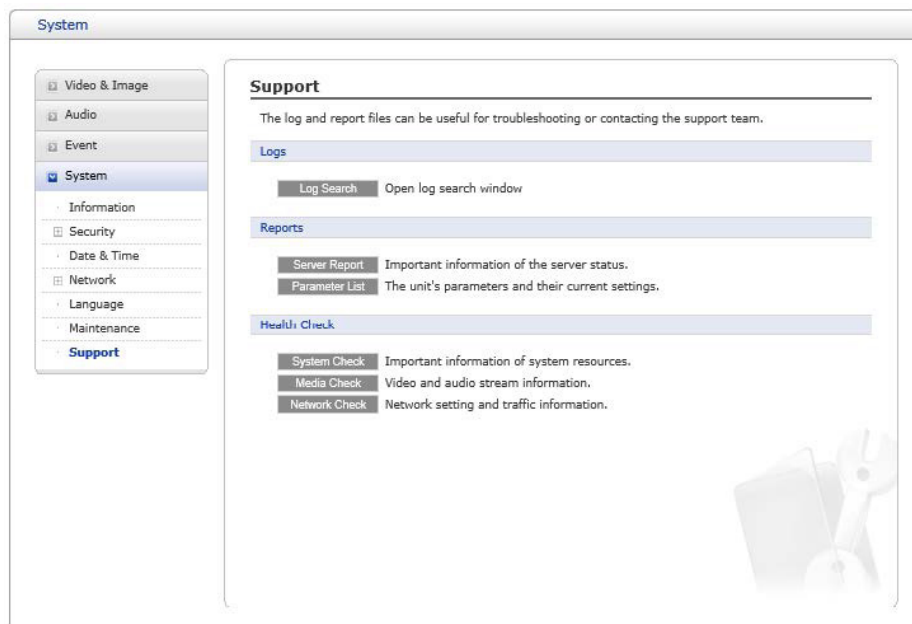

No.	Item	Description
1	Logs	<b>Log Search</b> The network camera supports system and event log information. Click the <b>log Search</b> button to search the Access, Event, Setup or Control log data.
2	Reports	<b>Server Report</b> Click the <b>Server Report</b> button to get the important information about the server's status; this should always be included when requesting support. <b>Parameter List</b> Click the <b>Parameter List</b> button to see the unit's parameters and their current settings.
3	Health Check	<b>System Check</b> Click the <b>System Check</b> button to get the important information about the cameras system resources. <b>Media Check</b> Click the <b>Media Check</b> button to get the information about the cameras video and audio stream. <b>Network Check</b> Click the <b>Network Check</b> button to get the information about the cameras network setting and traffic.

The Help information window will be provided as a popup window so that users can open and read it without needing to log-in. It will offer a description of the setting and Help page so that users can manipulate the network camera without a reference to the manual.

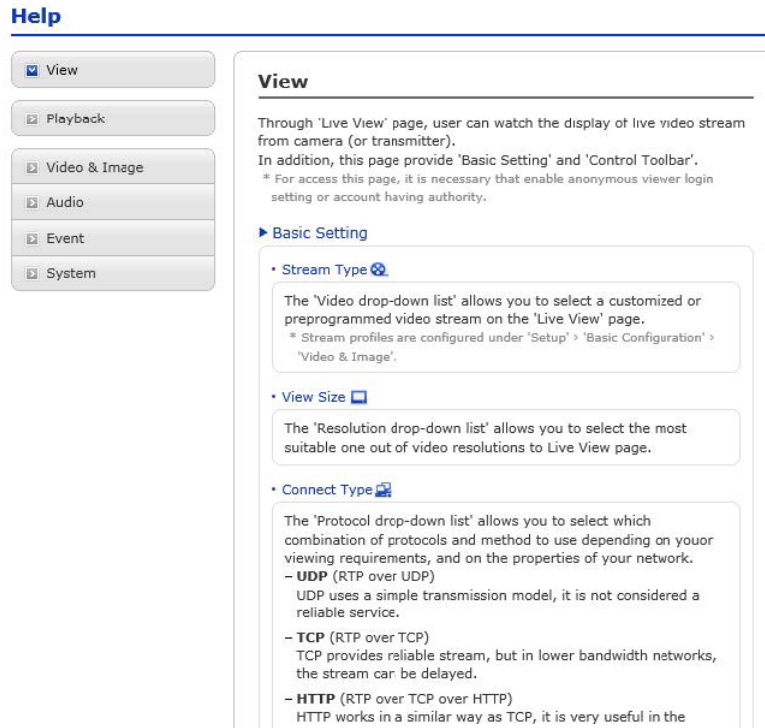



**Help**

- View
- Playback
- Video & Image
- Audio
- Event
- System

### View

Through 'Live View' page, user can watch the display of live video stream from camera (or transmitter).  
In addition, this page provide 'Basic Setting' and 'Control Toolbar'.  
\* For access this page, it is necessary that enable anonymous viewer login setting or account having authority.

▶ **Basic Setting**

- **Stream Type**   
The 'Video drop-down list' allows you to select a customized or preprogrammed video stream on the 'Live View' page.  
\* Stream profiles are configured under 'Setup' > 'Basic Configuration' > 'Video & Image'.
- **View Size**   
The 'Resolution drop-down list' allows you to select the most suitable one out of video resolutions to Live View page.
- **Connect Type**   
The 'Protocol drop-down list' allows you to select which combination of protocols and method to use depending on your viewing requirements, and on the properties of your network.  
– **UDP** (RTP over UDP)  
UDP uses a simple transmission model, it is not considered a reliable service.  
– **TCP** (RTP over TCP)  
TCP provides reliable stream, but in lower bandwidth networks, the stream can be delayed.  
– **HTTP** (RTP over TCP over HTTP)  
HTTP works in a similar way as TCP, it is very useful in the

## 2 - APPENDIX

### 2.1 - Troubleshooting

EN

Troubleshooting if problems occur, verify the installation of the network camera with the instructions in this manual and with other operating equipment. Isolate the problem to the specific piece of equipment in the system and refer to the equipment manual for further information.

Problem / Symptoms	Possible Causes or Corrective Actions
The camera cannot be accessed by some clients.	If using a proxy server, try disabling the proxy setting in your browser. Check all cabling and connectors.
The camera works locally, but not externally.	Check if there are firewall settings that need to be adjusted. Check if there are router settings that need to be configured.
Poor or intermittent network connection.	If using a network switch, check that the port on that device uses the same setting for the network connection type (speed / duplex).
The camera cannot be accessed via a host name.	Check that the host name and DNS server settings are correct.
Not possible to log in.	When HTTPS is enabled, ensure that the correct protocol(HTTP or HTTPS) is used. When attempting to log in, you may need to manually type in http or https in the browser's address bar.
No image using Refresh And / or slow updating of images.	If images are very complex, try limiting the number of clients accessing the camera.
Images only shown in Black & White.	Check the Video & Image setting
Blurred images.	Refocus the camera.
Poor image quality	Increased lighting can often improve image quality. Check that there is sufficient lighting at the monitored location. Check all image and lighting settings.
Rolling dark bands or flickering in image	Try adjusting the Exposure Control setting under AE and AWB part.
H.264 not displayed in the client.	Check that the correct network interface is selected in the Video & Image / Stream.
Multicast H.264 not displayed in the client.	Check with your network administrator that the multicast addresses used by the camera are valid for your network. Check that the Enable multicast checkbox are enabled in the System / Network / RTP tab. Checks with your network administrator to see if there is a firewall preventing viewing.
Multicast H.264 only accessible by local clients.	Check if your router supports multicasting, or if the router settings between the client and the server need to be con-figured. The TTL value may need to be increased.
Color saturation is different in H.264 and Motion JPEG.	Modify the settings for your graphics adapter. Please see the adapter's documentation for more information.
Video cannot be recorded.	Check that the Micro-SD card is inserted properly. Check that the Micro-SD card is formatted properly.

## 2.2 - Alarm Connection

The following connection diagram gives an example of how to connect a network camera.

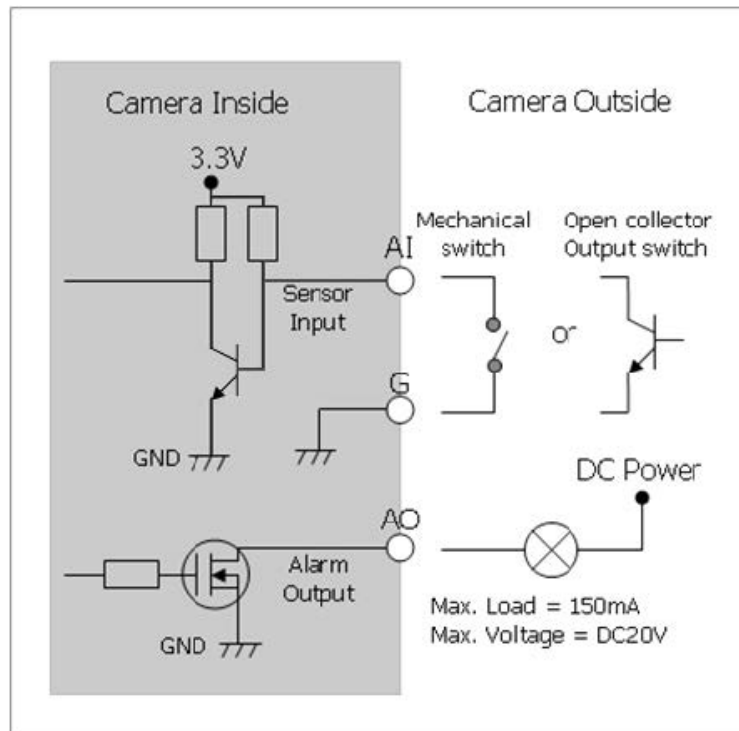

## 2.3 - Preventive Maintenance

Preventive maintenance allows detection and correction of minor that faults before they become serious and cause equipment failure.

Every three-month, perform the following maintenance.

1. Inspect all connection cables for deterioration or other damage.
2. Clean components with a clean damp cloth.
3. Verify that all the mounting hardware is secure.

## 2.4 - System Requirement for Web Browser

Item	Recommended	Minimum
OS	Microsoft® Windows 10 (Home, Professional)	Microsoft® Windows 7(x86, x64) (Home Premium)
CPU	intel® Core™ i5-6500	intel® Core™ i3-6100
RAM	8GB or Higher	4GB or Higher
VGA	NVIDIA GeForce GTX 960 or AMD Radeon R9 280X	NVIDIA GeForce GTX 670 or Radeon HD 7970
HDD	-	-
LAN	Gigabit Ethernet	Gigabit Ethernet

EN

## 2.5 - General Performance Considerations

When setting up your system, it is important to consider how various settings and situations will affect performance. Some factors affect the amount of bandwidth (the bit rate) required, others can affect the frame rate, and some affect both. If the load on the CPU reaches its maximum, this will also affect the frame rate.

The following factors are among the most important to consider:

1. High image resolutions and/or lower compression levels (or high bitrates) result in larger images. Frame rate and Bandwidth affected.
2. Accessing both Motion JPEG and H.264 video streams simultaneously. Frame rate and bandwidth affected.
3. Heavy network utilization due to poor infrastructure. Frame rate and Bandwidth affected.
4. Heavy network utilization via wireless router due to poor infrastructure. Frame rate and bandwidth affected.
5. Viewing on poorly performing client PCs lowers perceived performance. Frame rate affected.





eneo® is a registered trademark of  
VIDEOR E. Hartig GmbH  
Exclusive distribution through specialised  
trade channels only.

VIDEOR E. Hartig GmbH  
Carl-Zeiss-Straße 8  
63322 Rödermark / Germany  
Tel. +49 (0) 6074 / 888-0  
Fax +49 (0) 6074 / 888-100  
[www.videor.com](http://www.videor.com)  
[www.eneo-security.com](http://www.eneo-security.com)

Technical changes reserved

© Copyright by VIDEOR E. Hartig GmbH  
Version 04/2026